

**WAGO → I/O → SYSTEM 750**

**Library for  
Building Automation**

**Function Block Descriptions  
Common Building Functions**

Last Update 16.12.2004



## General

Copyright © 2002 by WAGO Kontakttechnik GmbH  
All rights reserved.

### **WAGO Kontakttechnik GmbH**

Hansastraße 27  
D-32423 Minden

Phone: +49 (0) 571/8 87 – 0

Fax: +49 (0) 571/8 87 – 1 69

E-Mail: [info@wago.com](mailto:info@wago.com)

Web: <http://www.wago.com>

### **Technical Support**

Phone: +49 (0) 571/8 87 – 5 55

Fax: +49 (0) 571/8 87 – 85 55

E-Mail: [support@wago.com](mailto:support@wago.com)

Every conceivable measure has been taken to ensure the correctness and completeness of this documentation. However, as errors can never be fully excluded we would appreciate any information or ideas at any time.

We wish to point out that the software and hardware terms as well as the trademarks of companies used and/or mentioned in the present manual are generally trademark or patent protected.

## WAGO-I/O-PRO 32 Library for Building Automation

## List of contents

<b>Important Comments</b>	<b>5</b>
Copyright.....	5
Personnel Qualification .....	5
Intended Use.....	5
<b>Common Function Blocks</b>	<b>6</b>
Alarm (Fault Indication Function Block).....	6
Sunblind .....	8
Click (Double Click Key Evaluation).....	11
Short/Long (Evaluation of a Short - Long Key Actuation).....	12
Ambient Light Control.....	14
Dimmer Single Switch .....	16
Dimmer Double Switch.....	19
Scene (Switching) .....	21
Scene (Dimming) .....	23
Scene No. (Scene Selection) .....	25
Linear 2 Point (Characteristic Curve) .....	26
Linear 10 Point (Characteristic Curve) .....	28
SendOnDelta (INTEGER) .....	30
SendOnDelta (WORD).....	31
Light_Central (Time Delayed Switching ON and OFF).....	32
Stairwell Light with Pre-Warning .....	34
Stairwell Light without Pre-Warning with Manual OFF .....	36
Latching Relay .....	38
Latching Relay with Feedback .....	40
Level Switch .....	42
Tableau .....	45
Delay (Switching ON/OFF Delay).....	47
Weather .....	48
Setting.....	50
Operating Time .....	53
Run Duration Control .....	56
Time .....	58
Time Switch .....	60
Random Function.....	62
UnpackSwitch .....	64
UnpackState .....	65

UnpackScene.....	66
UnpackSetting.....	67
SCPT_lev_percent.....	68
SCPT_temp .....	69
SCPT_temp_p.....	70
Constant light control for 0 – 10 V applications .....	71

# Important Comments

To ensure fast installation and start-up of the units described in this manual, we strongly recommend that the following information and explanation is carefully read and adhered to.

## Copyright

This manual is copyrighted, together with all figures and illustrations contained therein. Any use of this manual which infringes the copyright provisions stipulated herein, is not permitted. Reproduction, translation and electronic and photo-technical archiving and amendments require the written consent of WAGO Kontakttechnik GmbH. Non-observance will entail the right of claims for damages.

## Personnel Qualification

The use of the product detailed in this manual is exclusively geared to specialists having qualifications in PLC programming, electrical specialists or persons instructed by electrical specialists who are also familiar with the valid standards. WAGO Kontakttechnik GmbH declines all liability resulting from improper action and damage to WAGO products and third party products due to non-observance of the information contained in this manual.

## Intended Use

For each individual application, the components supplied are to work with a dedicated hardware and software configuration. Modifications are only admitted within the framework of the possibilities documented in the manuals. All other changes to the hardware and/or software and the non-conforming use of the components entail the exclusion of liability on part of WAGO Kontakttechnik GmbH.

Please direct any requirements pertaining to a modified and/or new hardware or software configuration directly to WAGO Kontakttechnik GmbH.

# Common Function Blocks

## Alarm (Fault Indication Function Block)

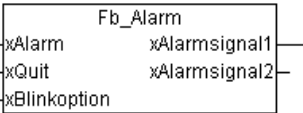
WAGO-I/O-PRO 32 Library Elements		
<b>Category:</b>	Building Automation	
<b>Name:</b>	Fb_Alarm	
<b>Type:</b>	Function <input type="checkbox"/>	Function block <input checked="" type="checkbox"/> Program <input type="checkbox"/>
<b>Library name:</b>	Building_common.lib	
<b>Applicable to:</b>	All programmable fieldbus controllers	
<b>Input Parameter:</b>	<b>Data type:</b>	<b>Comment:</b>
xAlarm	BOOL	TRUE at this input indicates an active alarm
xQuit	BOOL	Handshake signal for the alarm
xBlinkoption	BOOL	Selection of the flash option Default setting = FALSE
<b>Feedback Value:</b>	<b>Data type:</b>	<b>Comment:</b>
xAlarmsignal1	BOOL	Acoustic alarm signal preferred
xAlarmsignal2	BOOL	Visual alarm signal preferred
<b>Graphical Display:</b>		
		

## Time Referenced Behavior:

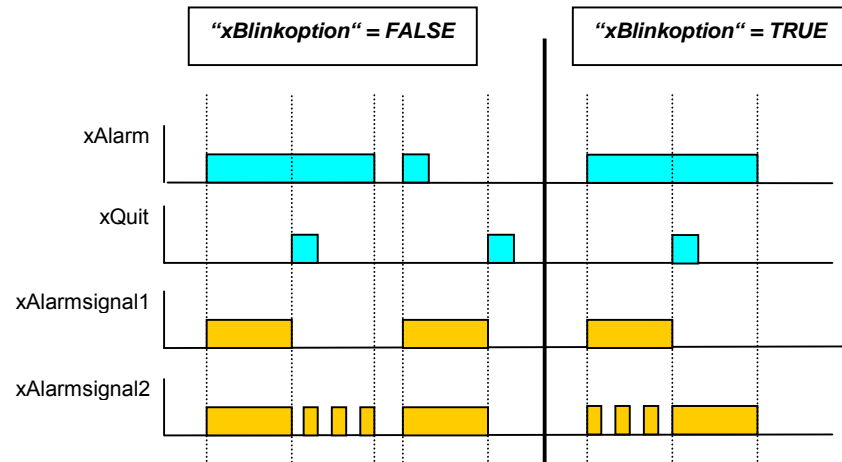

## Function Description:

If the signal at the `"xAlarm"` input changes to 1, both outputs `"xAlarmsignal1"` and `"xAlarmsignal2"` will be activated. Once the alarm is acknowledged by a signal at input `"xQuit"`, output `"xAlarmsignal1"` is reset. Should another alarm be pending, output `"xAlarmsignal2"` can adopt two different states: switched on or flashing (1 Hz). Depending on the selected option `"xBlinkoption"`, the flashing status of an alarm is:

- pending and acknowledged
- pending and not acknowledged

## Sunblind

<b>WAGO-I/O-PRO 32 Library Elements</b>			
<b>Category:</b>	Building Automation		
<b>Name:</b>	FbSunblind		
<b>Type:</b>	Function <input type="checkbox"/>	Function block <input checked="" type="checkbox"/>	Program <input type="checkbox"/>
<b>Library Name:</b>	Building_common.lib		
<b>Applicable to:</b>	All programmable fieldbus controllers		
<b>Input Parameter:</b>	<b>Data type:</b>	<b>Comment:</b>	
xSunblindSwitchUp	BOOL	Switch command Sunblind UP	
xSunblindSwitchDown	BOOL	Switch command Sunblind DOWN	
xMoveToShadowPosition	BOOL	Move to shadow position	
xSafety	BOOL	Signal input: safety position	
xManualAutomatic	BOOL	Switch-over Manual/Automatic	
uiT_WholePosTimeIn10telSec	UINT	Motor running time Value range: 0 – 3000 [0.1s] Default setting = 700	
uiT_WaittimeUpDownIn10telSec	UINT	Pause when changing direction Value range: 6 – 30 [0.1s] Default setting = 7	
uiT_SwitchShortIn10telSec	UINT	Time for brief key actuation Value range: 0 – 2000 [0.1s] Default setting = 5	
uiT_MoveShadowPosIn10telSec	UINT	Motor running time DOWN for shadow position Value range: 0 – 3000 [0.1s] Default setting = 300	
uiT_MoveShortIn10telSec	UINT	Sunblind setting time via switch command Value range: 0 – 30 [0.1s] Default setting = 2	
uiT_MoveTurnLamellaIn10telSec	UINT	Sunblind setting time, automatic Value range: 0 – 30 [0.1s] Default setting = 4	
xTurnAutomatic	BOOL	Turn automatic ON / OFF Default setting = FALSE	
<b>Feedback Value:</b>	<b>Data type:</b>	<b>Comment:</b>	
xDoSunblindUp	BOOL	Actuator command, sunblind UP	
xDoSunblindDown	BOOL	Actuator command, sunblind DOWN	
bPos_0_200	BYTE	Return information of the sunblind position 0 = sunblind up 200 = sunblind down	

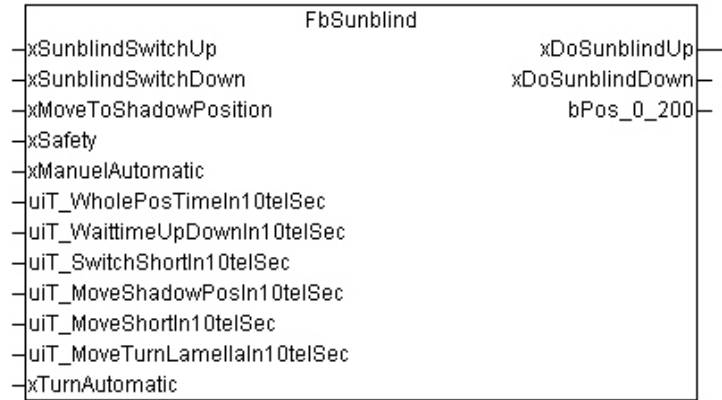

**Graphical Display:**

**Function Description:**

The sunblind function block is used to control roller blinds and sunblinds. The following functions are to be accomplished:

- UP/DOWN and sunblind setting
- Moving to a defined shadow position using the sunblind turn automatic (sun protection)
- Moving to safety position with interlocking feature (e.g. wind alarm)
- Selection possibility between manual/automatic mode
- Adjustable sunblind turn automatic after "DOWN" running time

Parameterization of running time, sunblind setting time and switch-over time is possible. The sunblind is accessed through the two input objects "**xSunblindSwitchUp**" and "**xSunblindSwitchDown**". With a "long 1" signal on these input objects (> as parameterized time "**uiT\_SwitchShortIn10telSec**") a signal is sent at the corresponding output "**xDoSunblindUp**" or "**xDoSunblindDown**". Here the sunblind motor is accessed for the running time "**uiT\_WholePosTimeIn10telSec**". If the input signal is shorter than the parameterized time, a stop telegram is sent or the sunblind is moved up or down for the period of "**uiT\_MoveShortIn10telSec**". Direct switching over from UP to DOWN and vice versa is possible, whereby the switch-over time "**uiT\_WaittimeUpDownIn10telSec**" is taken into consideration. The safety position (e.g. wind) can be accessed via the input object "**xSafety**". When the sunblind has been moved to the safety position, it cannot be manually controlled until the safety input has been reset.

The sunblind can be moved to the shadow or sun protection position via the position object "**xMoveToShadowPosition**". It is possible to determine by the configuration parameter "**xTurnAutomatic**" whether the sunblind lamellae are to be adjusted after the UP run for the "**uiT\_MoveTurnLamellaIn10telSec**" period.

The times for positioning and lamellae adjustment can be parameterized. The run command for sun protection is structured as followed:

1. Sunblind moves UP for the set running time **uiT\_WholePosTimeIn10telSec**
2. Wait for the end of the switch-over pause **uiT\_WaittimeUpDownIn10telSec**
3. Sunblind moves DOWN for the parameterized time "**uiT\_MoveShadowPosIn10telSec**"
4. Wait for the end of the switch-over pause **uiT\_WaittimeUpDownIn10telSec**
5. Then tilt the lamellae for the "**uiT\_MoveTurnLamellaIn10telSec**" period

The sun protection automatic can be switched off via input "**xManualAutomatic**" (0 / 1). In this manner you can avoid that the sunblind will automatically move in the cause of events, such as training courses or exams.

The output "**bJalPos\_0\_200**" returns the information of the rough position of the sunblind. The position is calculated from the running time (**uiT\_LfzGesamtIn\_10telSec**). The accuracy therefore depends on the registered running time and the difference in speed between opening and closing of the sunblind.

The behavior of the function module following a reset does not entail any change at the output.

## Click (Double Click Key Evaluation)

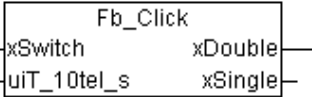
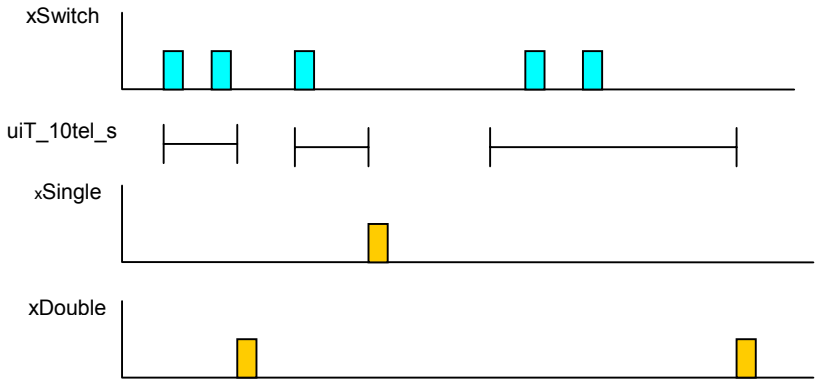
WAGO-I/O-PRO 32 Library Elements			
<b>Category:</b>	Building Automation		
<b>Name:</b>	FbClick		
<b>Type:</b>	Function <input type="checkbox"/>	Function block <input checked="" type="checkbox"/>	Program <input type="checkbox"/>
<b>Library Name:</b>	Building_common.lib		
<b>Applicable to:</b>	All programmable fieldbus controllers		
<b>Input Parameter:</b>			
	<b>Data type:</b>	<b>Comment:</b>	
xSwitch	BOOL	Switch signal input	
uiT_10tel_s	BOOL	Monitoring period for double click Value range: 5 - 50 [0.1s] Default setting = 10	
<b>Feedback Value:</b>			
	<b>Data type:</b>	<b>Comment:</b>	
xDouble	BOOL	Output shows single click	
xSingle	BOOL	Output shows double click	
<b>Graphical Display:</b>			
			
<b>Time Referenced Behavior:</b>			
			
<b>Function Description:</b>			
<p>The click function block detects if a single pulse or two sequential pulses occur on the binary input signal <b>"xSwitch"</b>.</p> <p>If only a single pulse occurs during the parameterizable time <b>"uiT_10tel_s"</b>, the <b>"xSingle"</b> output is set to 1 for the time of one task cycle. If two input pulses occur during the <b>"uiT_10tel_s"</b> time, the output signal <b>"xDouble"</b> is set to 1 for the time of one task cycle.</p>			

## Short/Long (Evaluation of a Short - Long Key Actuation)

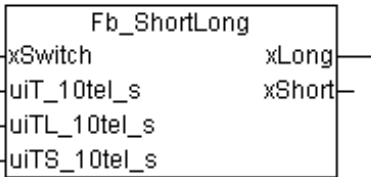
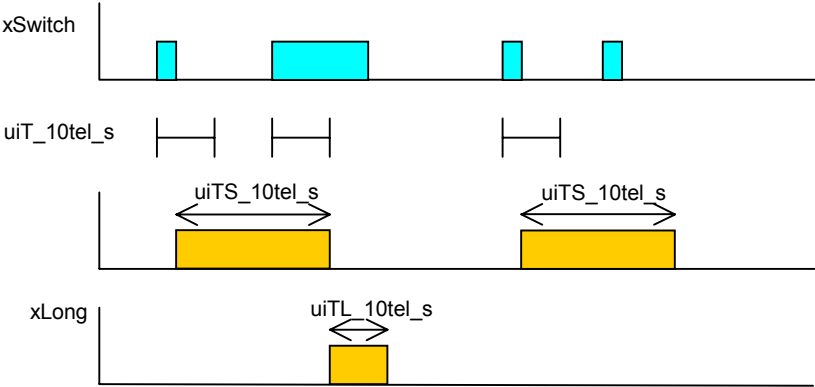
WAGO-I/O-PRO 32 Library Elements		
<b>Category:</b>	Building Automation	
<b>Name:</b>	ShortLong	
<b>Type:</b>	Function <input type="checkbox"/>	Function block <input checked="" type="checkbox"/> Program <input type="checkbox"/>
<b>Library Name:</b>	Building_common.lib	
<b>Applicable to:</b>	All programmable fieldbus controllers	
<b>Input Parameter:</b>	<b>Data type:</b>	<b>Comment:</b>
xSwitch	BOOL	Switch signal input
uiT_10tel_s	UINT	Time for a short key actuation Value range: 2 – 100 [0.1s] Default setting = 5
uiTL_10tel_s	UINT	Pulse duration of the “Long” output signal Value range: 0 – 65535 [0.1s] Default setting = 10
uiTS_10tel_s	UINT	Pulse duration of a “Short” output signal Value range: 0 – 65535 [0.1s] Default setting = 10
<b>Feedback Value:</b>	<b>Data type:</b>	<b>Comment:</b>
xLong	BOOL	Output signal with a long key actuation
xShort	BOOL	Output signal with a short key actuation
<b>Graphical Display:</b>		
		
<b>Time Referenced Behavior:</b>		
		

**Function Description:**

The ShortLong function block detects whether the “**xSwitch**” input signal is set shorter or longer than the specified “**uiT\_10tel\_s**” time. In this manner, short or long signals can be distinguished from switching sensors.

If the input signal is present for longer than the specified time, the output signal “**xLong**” is set to 1 for a default pulse duration “**uiTL\_10tel\_s**”. If it is present for a shorter time, a signal with the default pulse duration “**uiTS\_10tel\_s**” is sent via the output signal “**xShort**”.

## Ambient Light Control

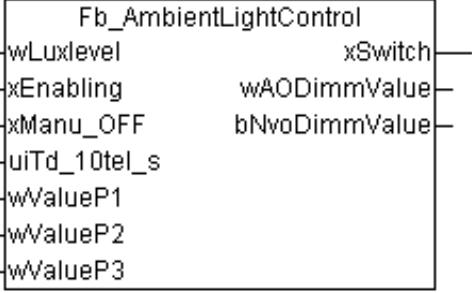
<b>WAGO-I/O-PRO 32 Library Elements</b>		
<b>Category:</b>	Building Automation	
<b>Name:</b>	Fb_AmbientLightControl	
<b>Type:</b>	Function <input type="checkbox"/>	Function block <input checked="" type="checkbox"/> Program <input type="checkbox"/>
<b>Library Name:</b>	Building_common.lib	
<b>Applicable to:</b>	All programmable fieldbus controllers	
<b>Input Parameter:</b>		
<b>Data type:</b>	<b>Comment:</b>	
wLuxlevel	WORD	Input signal of the light sensor Value range: 0 – 65535
xEnabling	BOOL	Release of the light control
xManu_OFF	BOOL	Automatic switch off at a wValueP3. 0 / 1 (yes / no)
uiTd_10tel_s	UINT	Switch-off delay when reaching wValueP3. Value range: 0 – 65535 [0.1s] Default setting = 3000
wValueP1	WORD	Ambient light value for lighting max. Value range: 0 – 65535 Default setting = 1000
wValueP2	WORD	Ambient light value for lighting 50% Value range: 0 – 65535 Default setting = 3000
wValueP3	WORD	Ambient light value for lighting min. Value range: 0 – 65535 Default setting = 10000
<b>Feedback Value:</b>		
<b>Data type:</b>	<b>Comment:</b>	
xSwitch	BOOL	Switching signal output
wAODimmValue	WORD	Dimming signal output internal on 1 – 10V Value range: 0 – 32767
bNvoDimmValue	BYTE	Dimming signal output via nvo to LON Value range: 0 – 200
<b>Graphical Display:</b>		
		

**Time Referenced Behavior:**

**Function Description:**

The function block permits the automatic light control dependent upon the ambient light. The current ambient light is polled via the **"wLuxlevel"** input. The light is controlled in line with the three parameterizable values:

- wValueP1** Full light at an ambient light of = .....
- wValueP2** Half light at an ambient light of = .....
- wValueP3** Switching off / basic light at an ambient light of = .....

**The three points (wValueP1 – wValueP3) have to be entered in an ascending order.** If this rule is disregarded, the outputs will change to a 0 signal.

The start point for the controls is defined by **"wValueP1"**. The ambient light is entered as **"wValueP2"**, where the dimming value is set to 50 %. A subsequent correction of the dimming characteristic line is preferentially made through point **"wValueP2"**. An ambient light value providing so much light in the room that the light can be switched off is entered at point **"wValueP3"**.

The light control is activated via a rising signal at input **"xEnabling"**. As standard, the lighting is only switched off when the basic light of point **"wValueP3"** is reached. Switching off occurs with a settable time delay of **"uiTd\_10tel\_s"**. The automatic switch-off can be suppressed by setting the **"xManu\_OFF"** input to the 1 signal. In this case the lighting is continued with the basic light (10%).

Optimum light adaptation of the lighting groups with regard to the window and the room side is possible by the combination of several of these function blocks.

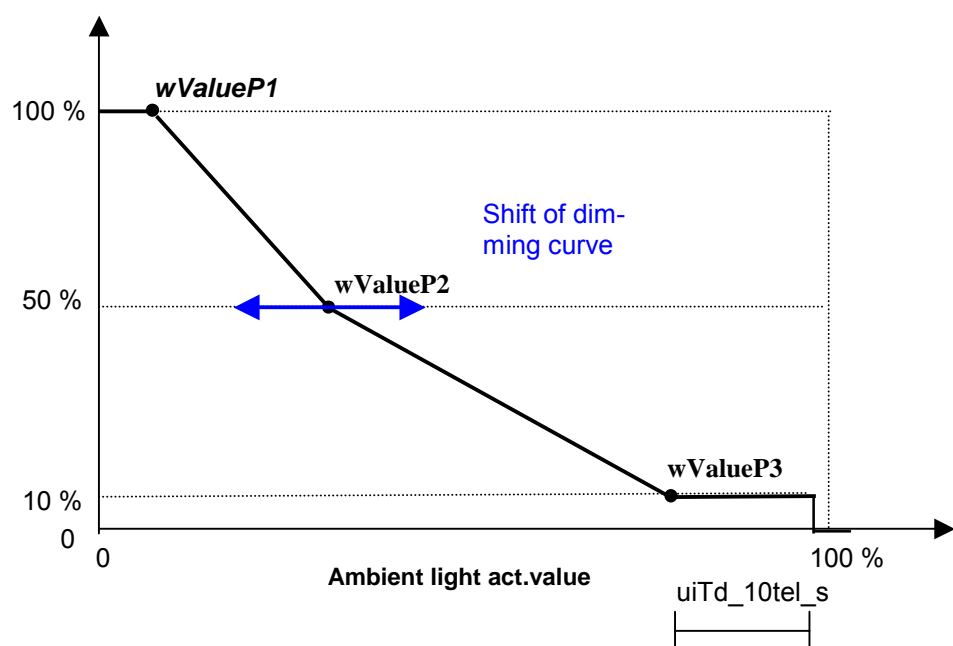

## Dimmer Single Switch

<b>WAGO-I/O-PRO 32 Library Elements</b>		
<b>Category:</b>	Building Automation	
<b>Name:</b>	FBDimmerSingleSwitch	
<b>Type:</b>	Function <input type="checkbox"/>	Function block <input checked="" type="checkbox"/> Program <input type="checkbox"/>
<b>Library Name:</b>	Building_common.lib	
<b>Applicable to:</b>	All programmable fieldbus controllers	
<b>Input Parameter:</b>	<b>Data type:</b>	<b>Comment:</b>
xDimmSwitch	BOOL	Switch signal switching/dimming
xSceneSwitch	BOOL	Scene switch
xCentON	BOOL	Central command, output activation
xCentOFF	BOOL	Central command, output deactivation
bDimmValue	BYTE	Setting output to value (0 – 200)
uiT_ShortIn10telSec	UINT	Time for a brief key actuation Value range: 3 – 100 [0.1s] Default setting = 5
xMemoOFF	BOOL	Deactivating memory function Default setting = TRUE
bMaxDimmValue	BYTE	Parameter value max. light Value range: 0 – 200 Default setting = 200
bMinDimmValue	BYTE	Parameter value minimum light Value range: 0 – 200 Default setting = 10
bDimmValueatMemoOFF	BYTE	Switch-on light (if no memory) Value range: 0 – 200 Default setting = 200
uiT_SpeedIn10telSec	UINT	Dimming time from Hmin → Hmax Value range: 30 – 1000 Default setting = 50
bModeOnReset	BYTE	Behavior after reset 0=AUS; 1=EIN; 3 = --- Default setting = 3
<b>Feedback Value:</b>	<b>Data type:</b>	<b>Comment:</b>
xSwitch	BOOL	Switching signal output
bNvo_DimmValue	BYTE	Dimmer signal output via nvo to LON Value range: 0 - 200
wAODimmValue	WORD	Dimmer signal output internally to 1 – 10V Value range: 0 - 32767



**Graphical Display:**

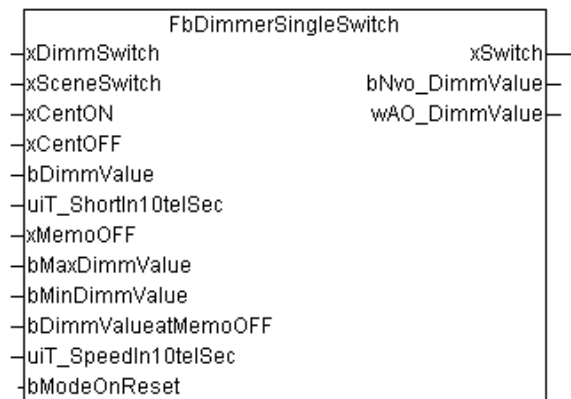

**Function Description:**

A lamp can be dimmed by means of the function block "DimmerEinfachTaster". The dimmer switch module evaluates short and long key actuation at the "**xDimmSwitch**" input. The input is protected by a debounce time of approx. 50ms. In the event of a long actuation of key, (parameterizable actuation time "**uiT\_ShortIn10telSec**") dimming up or down is performed by two output objects. The dimming value is set by two different data formats. In one of the formats, an adaptation is made to the SNVT\_switch ("**bNvo\_DimmValue**" 0-200), in the second, to the analog module 0-10V ("**wAODimmValue**" 0 - 32767). Following dimming up and stopping at the desired light, the next key actuation is a down dimming process. Dimming ON is possible by means of a long key actuation. If the key actuation is shorter than the parameterized time, an ON/OFF telegram is transmitted. The objects "**xCentON**" and "**xCentOFF**" allow to switch the function block, via a central command ON and OFF. The function block can also be addressed via a value object (e.g. from a scene module). If a light value is received on the "**bDimmValue**" object, the lighting switches ON at the corresponding light value. Subsequently the light can be changed again via the switch signal. This means that the value object only influences the output signal of the tip dimmer module in the event of a value change. The lighting can also be switched off via the value input, if the 0 value is received. It is possible, via the "**xSceneSwitch**" input, to re-activate the light value of the "**bDimmValue**" object as the output value of the tip dimmer module. This might become possible in conjunction with the scene module.

The last dimming value is saved when switching OFF and transmitted when switching ON again. This memory function can be de-activated for the purpose of parameterizing a fixed switch-on light. The switch-on light is determined by "**bDimmValueatMemoOFF**", prerequisite being that the memory function is de-activated.

The minimum and the maximum light level is entered as a default value by means of the parameters "**bMinDimmValue**" and "**bMaxDimmValue**".

Parameter "**uiT\_SpeedIn10telSec**" is the dimming time during which the light signal changes from "**bMinDimmValue**" to "**bMaxDimmValue**".

If for the time "**uiT\_SpeedIn10telSec**" a value outside of the value range (30 – 1000 [0.1s]) is entered, then the top or the bottom limit value is set.

Parameter "**bModeOnReset**" determines the function block behavior following a reset at the coupler. The following settings are possible for this parameter:

- 0 = Switching OFF following a reset
- 1 = Switching ON following a reset
- 3 = No change following a reset (the initial value before reset is restored)

**Note:**

This function block uses some residual variables having a **VAR\_RETAIN** declaration.

## Dimmer Double Switch

WAGO-I/O-PRO 32 Library Elements			
<b>Category:</b>	Building Automation		
<b>Name:</b>	FbDimmerDoubleSwitch		
<b>Type:</b>	Function <input type="checkbox"/>	Function block <input checked="" type="checkbox"/>	Program <input type="checkbox"/>
<b>Library Name:</b>	Building_common.lib		
<b>Applicable to:</b>	All programmable fieldbus controllers		
<b>Input Parameter:</b>			
	<b>Data type:</b>	<b>Comment:</b>	
xDimmSwitchUP	BOOL	Switch signal switching ON/OFF / Dimming UP	
xDimmSwitchDown	BOOL	Switch signal switching ON/OFF / Dimming DOWN	
xSceneSwitch	BOOL	Scene switch	
xCentON	BOOL	Central command, output activation	
xCentOFF	BOOL	Central command, output de-activation	
bDimmValue	BYTE	Setting output to value (0 – 200)	
uiT_ShortIn10telSec	UINT	Time for a brief key actuation Value range: 3 – 100 [0.1s] Default setting = 5	
xMemoOFF	BOOL	Deactivating memory function Default setting = TRUE	
bMaxDimmValue	BYTE	Parameter value maximum light Value range: 0 – 200 Default setting = 200	
bMinDimmValue	BYTE	Parameter value minimum light Value range: 0 – 200 Default setting = 10	
bDimmValueatMemoOFF	BYTE	Switch-on light (if no memory) Value range: 0 – 200 Default setting = 200	
uiT_SpeedIn10telSec	UINT	Dimming time from Hmin → Hmax Value range: 30 – 1000 Default setting = 50	
bModeOnReset	BYTE	Behavior after reset 0=OFF; 1=ON; 3 = --- Default value = 3	
<b>Feedback Value:</b>			
	<b>Data type:</b>	<b>Comment:</b>	
xSwitch	BOOL	Switching signal output	
bNvo_DimmValue	BYTE	Dimmer signal output via nvo to LON Value range: 0 - 200	
wAODimmValue	WORD	Dimmer signal output internally to 1 – 10V Value range: 0 - 32767	

**Graphical Display:**

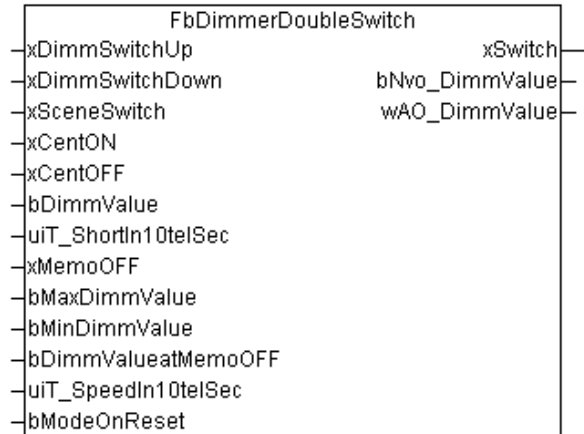

**Time Referenced Behavior:**

**Function Description:**

The function block “DimmerDoubleSwitch” is comparable to the function block “DimmerSingleSwitch”. The difference resides in the access of the function block with one double switch to both input objects “**xDimmSwitchUP**” and “**xDimmSwitchDown**”. This permits dimming UP or DOWN of the light in a defined manner. It is thus possible to always determine the dimming direction. A short pulse (< as “**uiT\_ShortIn10telSec**”) on one of the two inputs provokes switching the lighting ON or OFF. A long switch pulse (> as “**uiT\_ShortIn10telSec**”) on the “**xDimmSwitchUP**” input results in dimming UP up to “**bMaxDimmValue**” and a long switch pulse on “**xDimmSwitchDown**” in dimming DOWN to “**bMinDimmValue**”.

**Note:**

This function block uses some residual variables having a **VAR\_RETAIN** declaration.

## Scene (Switching)

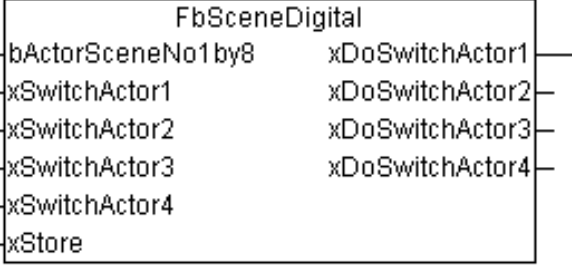
<b>WAGO-I/O-PRO 32 Library Elements</b>		
<b>Category:</b>	Building Automation	
<b>Name:</b>	FbSceneDigital	
<b>Type:</b>	Function <input type="checkbox"/>	Function block <input checked="" type="checkbox"/> Program <input type="checkbox"/>
<b>Library Name:</b>	Building_common.lib	
<b>Applicable to:</b>	All programmable fieldbus controllers	
<b>Input Parameter:</b>		
	<b>Data type:</b>	<b>Comment:</b>
bActorSceneNo1by8	BYTE	Selection of the desired light scene No. Value range: 1 - 8
xSwitchActor1	BOOL	Default value for actuator 1 with memory mode
xSwitchActor2	BOOL	Default value for actuator 2 with memory mode
xSwitchActor3	BOOL	Default value for actuator 3 with memory mode
xSwitchActor4	BOOL	Default value for actuator 4 with memory mode
xStore	BOOL	Memory mode poll
<b>Feedback Value:</b>		
	<b>Data type:</b>	<b>Comment:</b>
xDoSwitchActor1	BOOL	Switching signal actuator 1
xDoSwitchActor2	BOOL	Switching signal actuator 2
xDoSwitchActor3	BOOL	Switching signal actuator 3
xDoSwitchActor4	BOOL	Switching signal actuator 4
<b>Graphical Display:</b>		
		
<b>Time Referenced Behavior:</b>		

**Function Description:**

A lighting scenario can be polled by key actuation via the function block Scene. Eight scenes per module can be polled. The number of actuator groups is four. Individual light scene modules can be cascaded (run in parallel) if the number of scenes / actuator groups is insufficient.

The selection of the desired light scene number is made via the values 1-8 (BYTE) at the input **“bActorSceneNo1by8“**. The values internally stored or configured for the switching actuators **“xDoSwitchActor1-4“** are then activated.

The light scenes can be re-configured via the **“xSwitchActor1-4“**, whereby the input signals for the **“xSwitchActor1-4“** values are only evaluated when the operating mode ‘storing’ is active.

The procedure of entering new light scenes encompasses five steps:

1. Polling the light scene to be re-programmed
2. Activation of the input **“xStore“**
3. Entry of the values 1-4
4. Leaving the operating mode **“Store“**
5. The new scene is stored.

The following values are entered in the module as default values:

	Actuator 1	Actuator 2	Actuator 3	Actuator 4
<b>Scene 1</b>	OFF	OFF	OFF	OFF
<b>Scene 2</b>	ON	OFF	OFF	OFF
<b>Scene 3</b>	OFF	ON	OFF	OFF
<b>Scene 4</b>	OFF	OFF	ON	OFF
<b>Scene 5</b>	OFF	OFF	OFF	ON
<b>Scene 6</b>	OFF	OFF	ON	ON
<b>Scene 7</b>	OFF	ON	ON	ON
<b>Scene 8</b>	ON	ON	ON	ON

**Notes:**

- If you load a new program into the coupler, the programmed light scenes will be written over by the default values.
- This function block uses some residual variables having a **VAR\_RETAIN** declaration.

## Scene (Dimming)

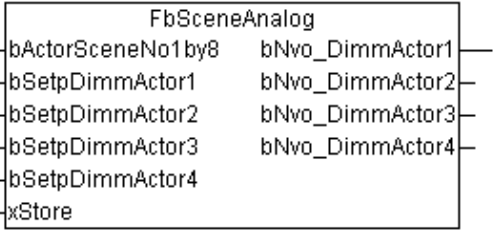
<b>WAGO-I/O-PRO 32 Library Elements</b>		
<b>Category:</b>	Building Automation	
<b>Name:</b>	FbSceneAnalog	
<b>Type:</b>	Function <input type="checkbox"/>	Function block <input checked="" type="checkbox"/> Program <input type="checkbox"/>
<b>Library Name:</b>	Building_common.lib	
<b>Applicable to:</b>	All programmable fieldbus controllers	
<b>Input Parameter:</b>	<b>Data type:</b>	<b>Comment:</b>
bActorSceneNo1by8	BYTE	Selection of the desired light scene No. Value range: 1 - 8
bSetpDimmActor1	BYTE	Default value for actuator 1 with memory mode Value range: 0 - 200
bSetpDimmActor2	BYTE	Default value for actuator 2 with memory mode Value range: 0 - 200
bSetpDimmActor3	BYTE	Default value for actuator 3 with memory mode Value range: 0 - 200
bSetpDimmActor4	BYTE	Default value for actuator 4 with memory mode Value range 0 - 200
xStore	BOOL	Memory mode poll
<b>Feedback Value:</b>	<b>Data type:</b>	<b>Comment:</b>
bNvo_DimmActor1	BYTE	Value for actuator 1 (0 – 200)
bNvo_DimmActor2	BYTE	Value for actuator 2 (0 – 200)
bNvo_DimmActor3	BYTE	Value for actuator 3 (0 – 200)
bNvo_DimmActor4	BYTE	Value for actuator 4 (0 – 200)
<b>Graphical dDisplay:</b>		
		
<b>Time Referenced Behavior:</b>		

**Function Description:**

A lighting scenario can be polled by key actuation via the function block Scene. Eight scenes per function block can be polled. The number of actuator groups is four. Individual light scene function blocks can be cascaded (run in parallel) if the number of scenes / actuator groups is insufficient.

Light scenes are polled via the values 1-8 (BYTE) at the **“bActorSceneNo1by8“** input.

The values internally stored or configured for the dimming actuators **“bNvo\_DimmAktor1-4“** are then actuated.

The light scenes can be re-configured via the **“bSetpDimmActor1-4“** inputs, whereby the input signals for **“bSetpDimmActor1-4“** are only evaluated if the operating mode ‘storing’ is active.

The procedure of entering new light scenes encompasses five steps:

1. Polling the light scene to be re-programmed
2. Activation of the input **“xStore“**
3. Entry of the dimming values actuator 1-4
4. Leaving the operating mode Store
5. The new scene is stored.

The following values are entered in the module as default values:

	Actuator 1	Actuator 2	Actuator 3	Actuator 4
<b>Scene 1</b>	0	0	0	0
<b>Scene 2</b>	10	30	50	70
<b>Scene 3</b>	30	50	70	90
<b>Scene 4</b>	50	70	90	110
<b>Scene 5</b>	70	90	110	130
<b>Scene 6</b>	90	110	130	150
<b>Scene 7</b>	110	130	150	170
<b>Scene 8</b>	200	200	200	200

**Notes:**

- If you load a new program into the coupler, the programmed light scenes will be written over by the default values.
- This function block uses some residual variables having a **VAR\_RETAIN** declaration.

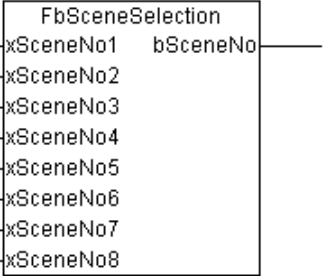

## Scene No. (Scene Selection)

WAGO-I/O-PRO 32 Library Elements		
<b>Category:</b>	Building Automation	
<b>Name:</b>	FbSceneSelection	
<b>Type:</b>	Function <input type="checkbox"/>	Function block <input checked="" type="checkbox"/> Program <input type="checkbox"/>
<b>Library Name:</b>	Building_common.lib	
<b>Applicable to:</b>	All programmable fieldbus controllers	
<b>Input Parameter:</b>	<b>Data type:</b>	<b>Comment:</b>
xSceneNo1	BOOL	Light scene selection 1
xSceneNo2	BOOL	Light scene selection 2
xSceneNo3	BOOL	Light scene selection 3
xSceneNo4	BOOL	Light scene selection 4
xSceneNo5	BOOL	Light scene selection 5
xSceneNo6	BOOL	Light scene selection 6
xSceneNo7	BOOL	Light scene selection 7
xSceneNo8	BOOL	Light scene selection 8
<b>Feedback Value:</b>	<b>Data type:</b>	<b>Comment:</b>
bSceneNo	BYTE	Output of the light scene number Value range: 1 - 8
<b>Graphical Display:</b>		
		
<b>Time Referenced Behavior:</b>		
<b>Function Description:</b>		
<p>The function block SceneSelection is used together with the function blocks "FbSzeneAnalog" or "FbSzeneDigital". It is intended to convert input <b>switch</b> signals of the BOOLEAN type into an output signal 1-8 of the Data type BYTE. This output signal allows the polling of the eight light scenes of the scene Function blocks. If two light scene inputs obtain an ON command at the same time, the scene with the larger number is turned OFF. If for instance the inputs "xSzeneNr2" and "xSzeneNr4" are active, the number four is turned OFF at the output "<b>bSceneNo</b>".</p>		
<p>Note: This function block used inside some variables with declaration <b>VAR_RETAIN</b>.</p>		

## Linear 2 Point (Characteristic Curve)

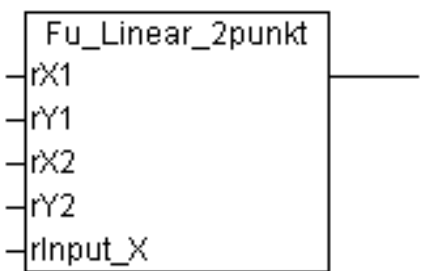
<b>WAGO-I/O-PRO 32 Library Elements</b>		
<b>Category:</b>	Building Automation	
<b>Name:</b>	Fu_Linear_2punkt	
<b>Type:</b>	Function <input checked="" type="checkbox"/>	Function block <input type="checkbox"/> Program <input type="checkbox"/>
<b>Library Name:</b>	Building_common.lib	
<b>Applicable to:</b>	All programmable fieldbus controllers	
<b>Input Parameter:</b>		
	<b>Data type:</b>	<b>Comment:</b>
rX1	REAL	Reference value X for point 1
rY1	REAL	Output value Y at point 1
rX2	REAL	Reference value X for point 2
rY2	REAL	Output value Y at point 2
rInput_X	REAL	Input signal before conversion
<b>Feedback Value:</b>		
	<b>Data type:</b>	<b>Comment:</b>
rY	REAL	Converted output signal
<b>Graphical Display:</b>		
		
<b>Time Referenced Behavior:</b>		

**Function Description:**

The input value “*rInput\_X*” is linearized according to the definitions in points *rX1*, *rY1* and *rX2*, *rY2*. This linearized value is directed to output “*rY*”.

If points *rX1* and *rY1* are identical (vertical characteristic curve), the output is set to 0.

If the values *rY1* and *rY2* are identical, the output is set to the value of *rY1* or *rY2*.

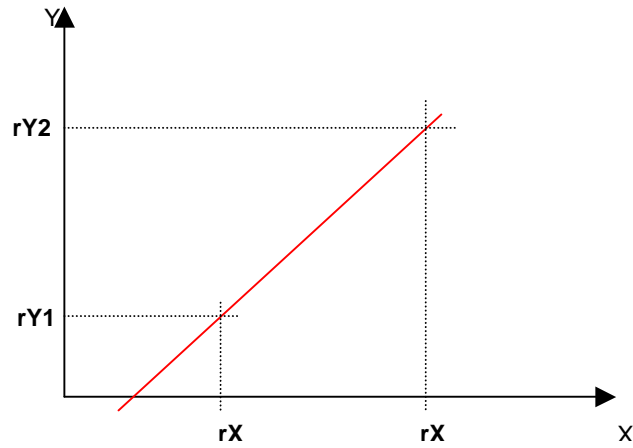

## Linear 10 Point (Characteristic Curve)

<b>WAGO-I/O-PRO 32 Library Elements</b>		
<b>Category:</b>	Building Automation	
<b>Name:</b>	Fu_Linear_10point	
<b>Type:</b>	Function <input checked="" type="checkbox"/>	Function block <input type="checkbox"/> Program <input type="checkbox"/>
<b>Library Name:</b>	Building_common.lib	
<b>Applicable to:</b>	All programmable fieldbus controllers	
<b>Input Parameter:</b>		
	<b>Data type:</b>	<b>Comment:</b>
rX1	REAL	Reference value X for point 1
rY1	REAL	Output value Y at point 1
...	...	...
...	...	...
rX10	REAL	Reference value X for point 10
rY10	REAL	Output value Y at point 10
rInput_X	REAL	Input signal before conversion
<b>Feedback Value:</b>		
	<b>Data type:</b>	<b>Comment:</b>
<b>Graphical Display:</b>		
<div style="border: 1px solid black; padding: 5px; width: fit-content;"> <p style="text-align: center;">Fu_Linear_10</p> <ul style="list-style-type: none"> <li>-rX1</li> <li>-rY1</li> <li>-rX2</li> <li>-rY2</li> <li>-rX3</li> <li>-rY3</li> <li>-rX4</li> <li>-rY4</li> <li>-rX5</li> <li>-rY5</li> <li>-rX6</li> <li>-rY6</li> <li>-rX7</li> <li>-rY7</li> <li>-rX8</li> <li>-rY8</li> <li>-rX9</li> <li>-rY9</li> <li>-rX10</li> <li>-rY10</li> <li>-rInput_X</li> </ul> </div>		

**Time Referenced Behavior:**

**Function Description:**

Straight segments are defined by the points (rX1, rY1) to (rX10, rY10). The input value "rInput X" is divided into segments, linearized and set at output "rY" by means of these points. As such, the entered points determine the value of the output signal  $Y=f(x)$ . **Ensure that the reference points X are always entered in an ascending order.** Reference points Y may be entered in any order. Outside of the defined area, the points of the last segment are applied. To limit the output value outside of the defined segments, it is recommended that the last two Y points have identical values.

If two consequential X points are identical, the output value is set to 0.

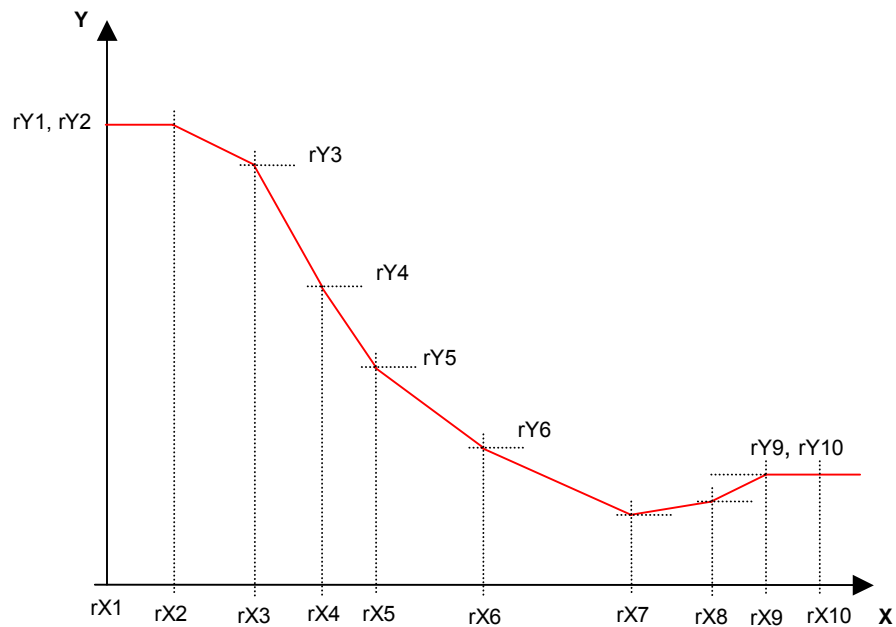

## SendOnDelta (INTEGER)

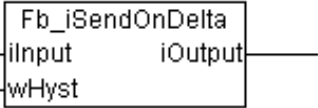
<b>WAGO-I/O-PRO 32 Library elements</b>		
<b>Category:</b>	Building Automation	
<b>Name:</b>	Fb_iSendOnDelta	
<b>Type:</b>	Function <input type="checkbox"/>	Function block <input checked="" type="checkbox"/> Program <input type="checkbox"/>
<b>Library Name:</b>	Building_common.lib	
<b>Applicable to:</b>	All programmable fieldbus controllers	
<b>Input Parameter:</b>		
	<b>Data type:</b>	<b>Comment:</b>
iInput	INT	Signal input (-32768 – 32767)
wHyst	WORD	Hysteresis for signal input ( 0 – 65535) Default setting = 0
<b>Feedback Value:</b>		
	<b>Data type:</b>	<b>Comment:</b>
iOutput	INT	Output signal (-32768 – 32767)
<b>Graphical Display:</b>		
		
<b>Time Referenced Behavior:</b>		
<b>Function Description:</b>		
<p>The function block SendOnDelta transmits the input signal <b>“iInput”</b> to the output signal <b>“iOutput”</b>. Small changes of the value at the input signal have, however, no effect on the output. A preset value via the parameter <b>“wHyst”</b> indicates the value change at the input signal at which the output signal will be reset .</p>		
<p><u>Example:</u> The input signal and the output signal have the value 3000. and the hysteresis is set to 100. If the input value changes in the range of 2951 - 3049, this will not affect the output signal. The output value of 3000 remains unchanged. The input signal is only transmitted to the output if value changes of <math>\geq 50</math> (hysteresis/2) occur.</p>		

## SendOnDelta (WORD)

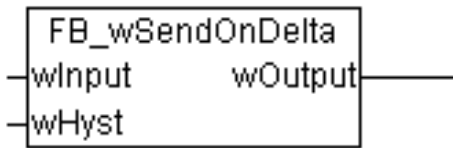
WAGO-I/O-PRO 32 Library elements		
<b>Category:</b>	Building Automation	
<b>Name:</b>	Fb_wSendOnDelta	
<b>Type:</b>	Function <input type="checkbox"/>	Function block <input checked="" type="checkbox"/> Program <input type="checkbox"/>
<b>Library Name:</b>	Building_common.lib	
<b>Applicable to:</b>	All programmable fieldbus controllers	
<b>Input Parameter:</b>	<b>Data type:</b>	<b>Comment:</b>
wInput	WORD	Signal input (0 – 65535)
wHyst	WORD	Hysteresis for signal input
<b>Feedback Value:</b>	<b>Data type:</b>	<b>Comment:</b>
wOutput	WORD	Signal output
<b>Graphical display:</b>		
		
<b>Time Referenced Behavior:</b>		
<b>Function Description:</b>		
<p>The function block wSendOnDelta transmits the input signal “<b>wInput</b>” to the output signal “<b>wOutput</b>”. Minor value changes at the input signal do not, however, affect the output. A preset value via the parameter “<b>wHyst</b>” indicates the value change at the input signal at which the output signal will be reset .</p> <p>Example:  The input signal and the output signal have the value 3000. and the hysteresis is set to 100. If the input value changes in the range of 2951 - 3049, this will not affect the output signal. The output value of 3000 remains unchanged. The input signal is only transmitted to the output if value changes of <math>\geq 50</math> (hysteresis/2) occur.</p>		

## Light\_Central (Time Delayed Switching ON and OFF)

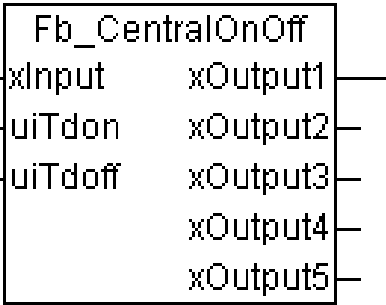
WAGO-I/O-PRO 32 Library Elements		
<b>Category:</b>	Building Automation	
<b>Name:</b>	Fb_CentralOnOff	
<b>Type:</b>	Function <input type="checkbox"/>	Function block <input checked="" type="checkbox"/> Program <input type="checkbox"/>
<b>Library Name:</b>	Building_common.lib	
<b>Applicable to:</b>	All programmable fieldbus controllers	
<b>Input Parameter:</b>		
	<b>Data type:</b>	<b>Comment:</b>
xInput	BOOL	Input switching signal
uiTdon_10tel_s	UINT	Delay time for switching ON Value range: 5 – 200 [0.1s] Default setting = 10
uiTdoff_10tel_s	UINT	Delay time for switching OFF Value range: 5 – 200 [0.1s] Default setting = 10
<b>Feedback Value:</b>		
	<b>Data type:</b>	<b>Comment:</b>
xOutput1	BOOL	Output switching signal 1
xOutput2	BOOL	Output switching signal 2
xOutput3	BOOL	Output switching signal 3
xOutput4	BOOL	Output switching signal 4
xOutput5	BOOL	Output switching signal 5
<b>Graphical Display:</b>		
		

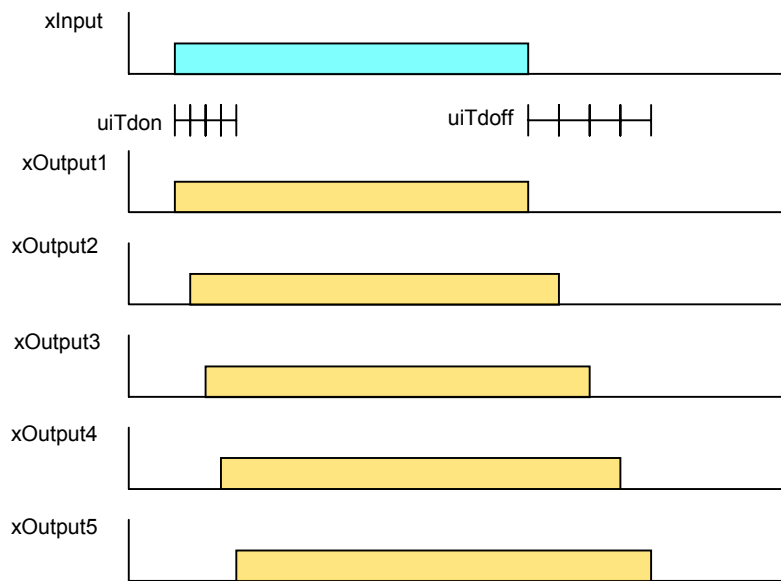

**Time Referenced Behavior:****Function description:**

When an ON telegram is received at the input object, the five output objects are sequentially switched ON with the time delayed. The delay time between the switching cycles can be set. A typical application for this module is the avoidance of load peak when centrally switching too extensive lighting circuits.

Also, with an OFF telegram at the input object, the outputs can be sequentially turned OFF in order to avoid voltage peaks by switching off large consumer circuits. The delay time can be set to 0 if the delay is not desired when switching off.

## Stairwell Light with Pre-Warning

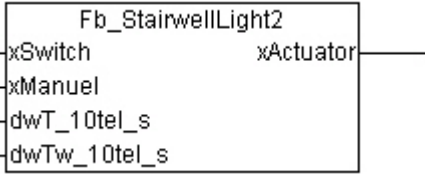
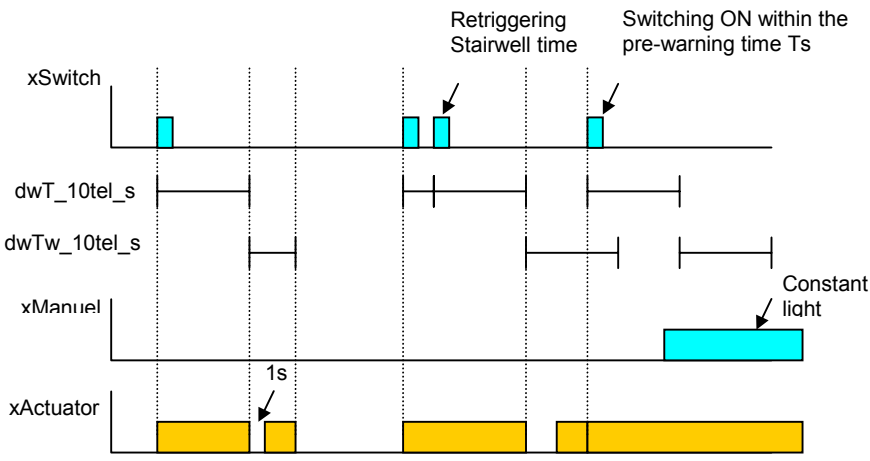
WAGO-I/O-PRO 32 Library Elements		
<b>Category:</b>	Building Automation	
<b>Name:</b>	Fb_StairwellLight2	
<b>Type:</b>	Function <input type="checkbox"/>	Function block <input checked="" type="checkbox"/> Program <input type="checkbox"/>
<b>Library Name:</b>	Building_common.lib	
<b>Applicable to:</b>	All programmable fieldbus controllers	
<b>Input Parameter:</b>	<b>Data type:</b>	<b>Comment:</b>
xSwitch	BOOL	Input for switching signal
xManual	BOOL	Switching command, constant light
dwT_10tel_s	DWORD	Stairwell time Value range: 10 – 65535 [0.1s] Default setting = 1200
dwTw_10tel_s	DWORD	Pre-warning time 50 – 300 [0.1s] Default setting = 150
<b>Feedback Value:</b>	<b>Data type:</b>	<b>Comment:</b>
xActuator	BOOL	Output switching signal
<b>Graphical Display:</b>		
		
<b>Time Referenced Behavior:</b>		
		

**Function Description:**

The output "**xActuator**" is set to 1 with a rising signal at input "**xSwitch**". Once the settable stairwell time has elapsed, "**dwT\_10tel\_s**", a switch-off pre-warning occurs in that the output is reset to 0 for the duration of 1 second. Subsequently the output for the pre-warning duration "**dwTw\_10te\_s**" is switched on. If another rising signal is detected at input "**xSwitch**" during this period, the stairwell time will be re-triggered. If the time is not re-triggered, the output switches back to 0 once the pre-warning time "**dwTw\_10tel\_s**" has elapsed. The output is set (constant light) for as long as an ON signal is pending on input "**xManual**".

## Stairwell Light without Pre-Warning with Manual OFF

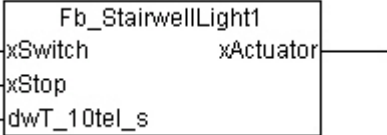
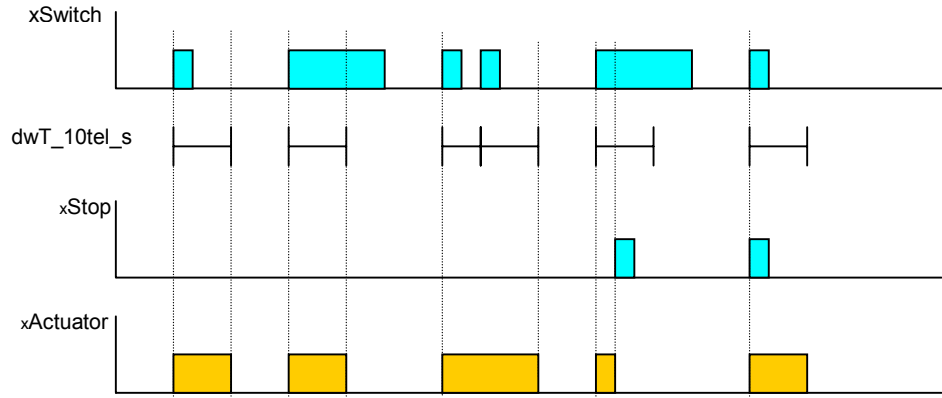
<b>WAGO-I/O-PRO 32 Library Elements</b>		
<b>Category:</b>	Building Automation	
<b>Name:</b>	Fb_StairwellLight1	
<b>Type:</b>	Function <input type="checkbox"/>	Function block <input checked="" type="checkbox"/> Program <input type="checkbox"/>
<b>Library Name:</b>	Building_common.lib	
<b>Applicable to:</b>	All programmable fieldbus controllers	
<b>Input Parameter:</b>		
<b>Data type:</b>	<b>Comment:</b>	
xSwitch	BOOL	Input for switching signal
xStop	BOOL	Stopping the stairwell time
dwT_10tel_s	DWORD	Stairwell time Value range: 10 – 65535 [0.1s] Default setting = 1200
<b>Feedback Value:</b>		
<b>Data type:</b>	<b>Comment:</b>	
xActuator	BOOL	Output switching signal
<b>Graphical Display:</b>		
		
<b>Time Referenced Behavior:</b>		
		

**Function Description:**

The function block 'stairwell' operates as a dynamic, mono-stable flip flop. With a rising signal at input **"xSwitch"** at the output **"xActuator"** is turned ON. The duration of the stairwell time is set via parameter **"dwT\_10tel\_s"**. Should another rising signal occur at the input during the stairwell time, the time is reset and the pulse extended (retriggerable).

The stop input sets the output signal to zero at any time (stairwell light with manual OFF).

With the output set and the arrival of a signal on inputs **"xSwitch"** and **"xStop"** the stop input has the priority and the stairwell time will be discontinued. If the output is not set and if the inputs are simultaneously set with a 1, the output is set and the stairwell time started.

## Latching Relay

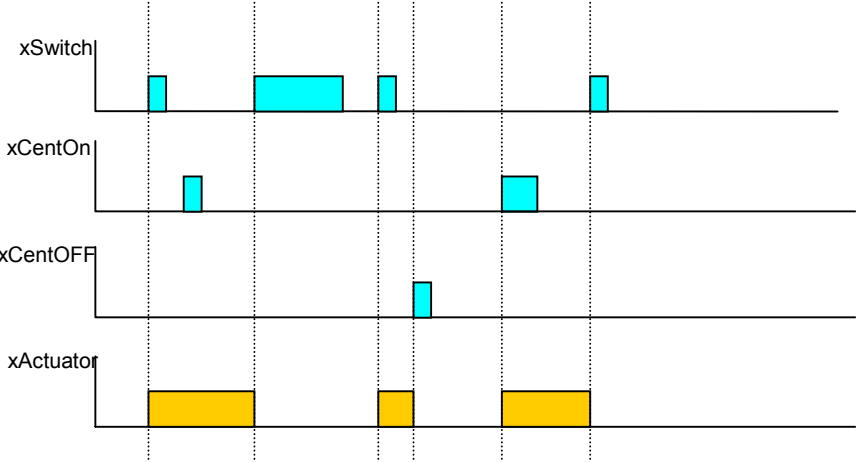
WAGO-I/O-PRO 32 Library elements		
<b>Category:</b>	Building Automation	
<b>Name:</b>	Fb_LatchingRelay	
<b>Type:</b>	Function <input type="checkbox"/>	Function block <input checked="" type="checkbox"/> Program <input type="checkbox"/>
<b>Library Name:</b>	Building_common.lib	
<b>Applicable to:</b>	All programmable fieldbus controllers	
<b>Input Parameter:</b>		
	<b>Data type:</b>	<b>Comment:</b>
xSwitch	BOOL	Input for switching signal
xCentOFF	BOOL	Switching signal Central OFF
xCentON	BOOL	Switching signal Central ON
bModeOnReset	BYTE	Behavior after reset 0=AUS; 1=EIN; 3 = --- Default setting = 3
<b>Feedback Value:</b>		
	<b>Data type:</b>	<b>Comment:</b>
xActuator	BOOL	Output switching signal
<b>Graphical Display:</b>		
		
<b>Time Referenced Behavior:</b>		
		

**Function Description:**

The function block Latching Relay is identical to that of a toggle flip flop. The function block reacts on the switching signal at the "**xSwitch**" input with a change over function. The input is protected by a debounce time of approx. 30ms. The output signal "**xActuator**" changes its value with every positive switching signal at the input.

The output signal can be switched via the input objects "**xCentON**" or "**xCentOFF**".

Parameter "**bModeOnReset**" determines the function blocks behavior following a reset at the coupler. The following settings are possible for this parameter:

0 = Switching OFF following a reset

1 = Switching ON following a reset

3 = No change following a reset (the initial value before reset is restored)

**Note:**

This function block uses some residual variables having a **VAR\_RETAIN** declaration.

## Latching Relay with Feedback

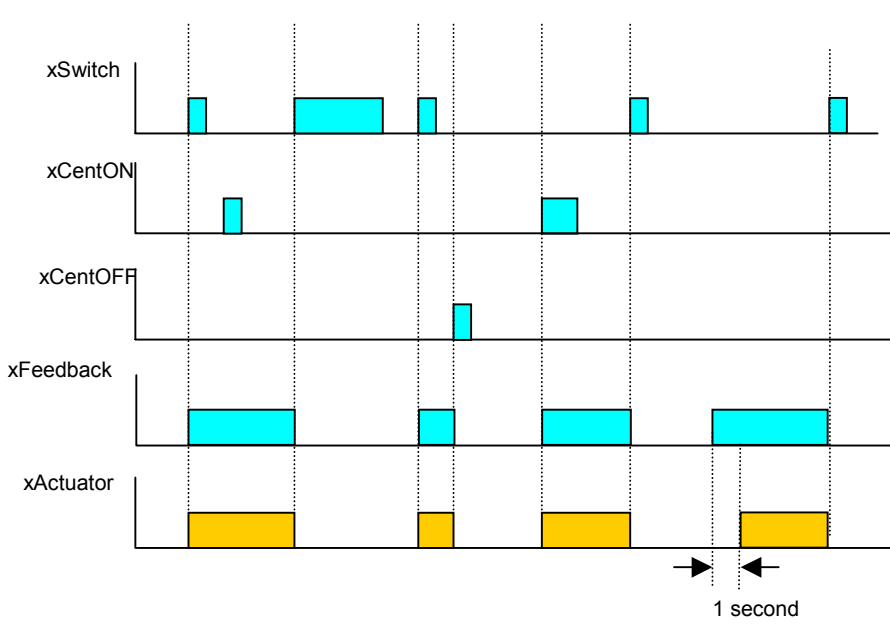
WAGO-I/O-PRO 32 Library elements			
<b>Category:</b>	Building Automation		
<b>Name:</b>	Fb_LatchingRelayFeedb		
<b>Type:</b>	Function <input type="checkbox"/>	Function block <input checked="" type="checkbox"/>	Program <input type="checkbox"/>
<b>Library Name:</b>	Building_common.lib		
<b>Applicable to:</b>	All programmable fieldbus controllers		
<b>Input Parameter:</b>			
	<b>Data type:</b>	<b>Comment:</b>	
xSwitch	BOOL	Input for switching signal	
xCentOFF	BOOL	Switching signal Central OFF	
xCentON	BOOL	Switching signal Central ON	
bFeedback	BOOL	Input for Feedback signal	
<b>Feedback Value:</b>			
	<b>Data type:</b>	<b>Comment:</b>	
xActuator	BOOL	Output switching signal	
<b>Graphical Display:</b>			
<div style="border: 1px solid black; padding: 5px; width: fit-content;"> <p>Fb_LatchingRelayFeedb</p> <p>—xSwitch      xActuator</p> <p>—xCentOFF</p> <p>—xCentON</p> <p>—xFeedback</p> </div>			
<b>Time Referenced Behavior:</b>			
			



### Function Description:

The function block Latching Relay with Feedback is identical to that of a toggle flip flop. The function block reacts on the switching signal at the “**xSwitch**” input with a change over function. The input is protected by a debounce time of approx. 30ms. The output signal “**xActor**” changes its value with every positive switching signal at the input.

The function block can only be used if a feedback signal of the actuator is available. If the values of the output signal **xAktor** and the input signal “**xFeedback**” differ longer than 1 second, the output signal will be set equal to the feedback input signal. A typical application is the control of an external actuator using several distributed sensors (see example below).

The output signal can be switched via the input objects “**xCentON**” or “**xCentOFF**”.

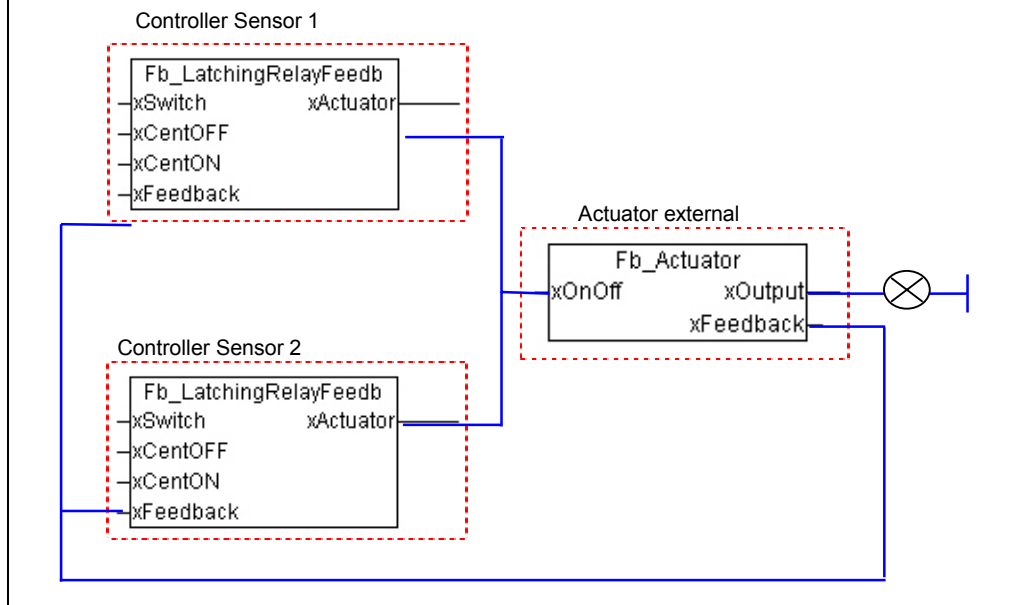

## Level Switch

WAGO-I/O-PRO 32 Library elements		
<b>Category:</b>	Building Automation	
<b>Name:</b>	Fb_SwitchLevel	
<b>Type:</b>	Function <input type="checkbox"/>	Function block <input checked="" type="checkbox"/> Program <input type="checkbox"/>
<b>Library Name:</b>	Building_common.lib	
<b>Applicable to:</b>	All programmable fieldbus controllers	
<b>Input Parameter:</b>		
	<b>Data type:</b>	<b>Comment:</b>
iInput	INT	Input signal
iSetp1	INT	Threshold value level 1 Value range: -32768 – 32767 Default setting = 200
iSetp2	INT	Threshold value level 2 Value range: -32768 – 32767 Default setting = 220
iSetp3	INT	Threshold value level 3 Value range: -32768 – 32767 Default setting = 240
iSetp4	INT	Threshold value level 4 Value range: -32768 – 32767 Default setting = 260
iSetp5	INT	Threshold value level 5 Value range: -32768 – 32767 Default setting = 280
iHyst	INT	Hysteresis for threshold values Value range: 0 – 32767 Default setting = 20
xL1	BOOL	Manual operation level 1
xL2	BOOL	Manual operation level 2
xL3	BOOL	Manual operation level 3
xL4	BOOL	Manual operation level 4
xL5	BOOL	Manual operation level 5
xManual	BOOL	Manual mode activation
uiTd_10tel_s	UINT	Switch-over time between levels Value range: 5 – 100 [0.1s] Default setting = 20
<b>Feedback Value:</b>		
	<b>Data type:</b>	<b>Comment:</b>
xLevel1	BOOL	Switching output level 1
xLevel2	BOOL	Switching output level 2
xLevel3	BOOL	Switching output level 3
xLevel4	BOOL	Switching output level 4
xLevel5	BOOL	Switching output level 5
xError	BOOL	Error message, incorrect input

**Graphical Display:**

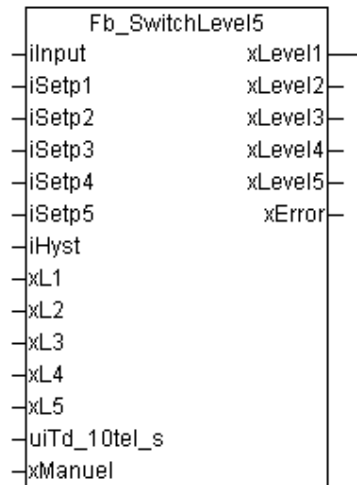

**Time Referenced Behavior:**

Example: Diagram of a 2 level switch

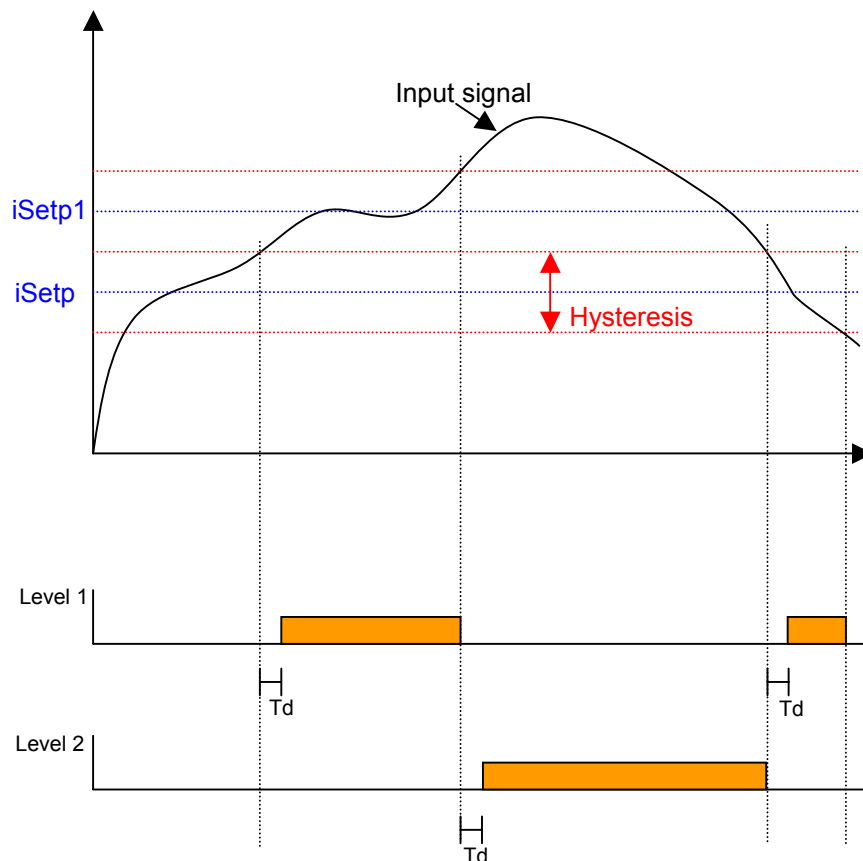

**Function Description:**

The function block Level Switch is available in the library in a 2-5 level version. It compares an analog input value "*iInput*" with the threshold values "*iSetp1-iSetpX*". If a threshold value + hysteresis/2 is exceeded, the corresponding level 1-X is set to "1".

The input value can fluctuate within the hysteresis without the level output changing. The hysteresis applies jointly for all threshold values.

If the threshold value - hysteresis/2 is less than the threshold value of the lower level, the next level below switches on.

It is not possible to have several levels set to "1" at the same time.

A delay time for switching between the individual levels can be entered as a default value via parameter "*uiTd\_10tel\_s*".

The **threshold values must be entered in an ascending order**. If this rule is not observed, a message will be emitted via the "Error" output object.

Example:**Hysteresis = 2**

**iSetp1 = 20**

**19** ⇒ xLevel1 = OFF

**21** ⇒ xLevel1 = ON

**iSetp2 = 22**

**21** ⇒ xLevel2 = OFF

**23** ⇒ xLevel2 = ON

**iSetp3 = 24**

**23** ⇒ xLevel3 = OFF

**25** ⇒ xLevel3 = ON

**iSetp4 = 26**

**25** ⇒ xLevel4 = OFF

**27** ⇒ xLevel4 = ON

**iSetp5 = 28**

**27** ⇒ xLevel5 = OFF

**29** ⇒ xLevel5 = ON

If possible, the spacing between the threshold values should have the same value as the hysteresis.

# Tableau

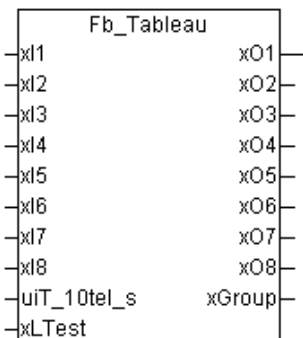
<b>WAGO-I/O-PRO 32 Library Elements</b>		
<b>Category:</b>	Building Automation	
<b>Name:</b>	Fb_Tableau	
<b>Type:</b>	Function <input type="checkbox"/>	Function block <input checked="" type="checkbox"/> Program <input type="checkbox"/>
<b>Library Name:</b>	Building_common.lib	
<b>Applicable to:</b>	All programmable fieldbus controllers	
<b>Input Parameter:</b>	<b>Data type:</b>	<b>Comment:</b>
xI1	BOOL	Input message 1
xI2	BOOL	Input message 2
xI3	BOOL	Input message 3
xI4	BOOL	Input message 4
xI5	BOOL	Input message 5
xI6	BOOL	Input message 6
xI7	BOOL	Input message 7
xI8	BOOL	Input message 8
xLTest	BOOL	Input for lamp test poll
uiT_10tel_s	UINT	Time for pulse/pause flashing signal Value range: 0 – 100 [0.1s] Default setting = 0
<b>Feedback Value:</b>	<b>Data type:</b>	<b>Comment:</b>
xO1	BOOL	Indicator lamp 1
xO2	BOOL	Indicator lamp 2
xO3	BOOL	Indicator lamp 3
xO4	BOOL	Indicator lamp 4
xO5	BOOL	Indicator lamp 5
xO6	BOOL	Indicator lamp 6
xO7	BOOL	Indicator lamp 7
xO8	BOOL	Indicator lamp 8
xGroup	BOOL	Output collective fault indication
<b>Graphical Display:</b>		
		

**Time referenced Behavior:****Function Description:**

The function block Tableau converts 8 binary input commands into switching states (lamp ON / lamp OFF / lamp flashing). The parameterized switching status is indicated when the binary switching telegram arrives. The function of the connected lamps can be checked via the input lamp test. If the input **"xLTest"** receives a "1" signal, all 8 outputs switch ON.

The flashing frequency is jointly set for all outputs. The output signal collective fault indication **"xGroup"** is set to "1" if one of the inputs is switched active. If 0 is entered as a default value for parameter **"uiT\_10tel\_s"**, the outputs **"xO1 – xO8"** will switch permanently ON when accessing the corresponding input.

## Delay (Switching ON/OFF Delay)

WAGO-I/O-PRO 32 Library Elements			
<b>Category:</b>	Building Automation		
<b>Name:</b>	Fb_Delay		
<b>Type:</b>	Function <input type="checkbox"/>	Function block <input checked="" type="checkbox"/>	Program <input type="checkbox"/>
<b>Library Name:</b>	Building_common.lib		
<b>Applicable to:</b>	All programmable fieldbus controllers		
<b>Input Parameter:</b>			
	<b>Data type:</b>	<b>Comment:</b>	
xInput	BOOL	Switching signal input	
dwTon_10tel_s	DWORD	Value for switching ON delay Value range: 0 – 65535 [0.1s] Default setting = 10	
dwTOff_10tel_s	DWORD	Value for switching OFF delay Value range: 0 – 65535 [0.1s] Default setting = 10	
<b>Feedback Value:</b>			
	<b>Data type:</b>	<b>Comment:</b>	
xOutput	BOOL	Output switching signal	
<b>Graphical Display:</b>			
<b>Time Referenced Behavior:</b>			
<b>Function Description:</b>			
<p>The Delay function block delays the rising and falling signal (switching ON/OFF delay) of the input signal “xInput“. The delay times for rising and falling are individually settable. Both times can also be set to 0.</p>			

## Weather

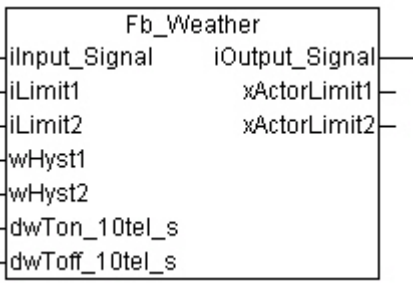
<b>WAGO-I/O-PRO 32 Library Elements</b>			
<b>Category:</b>	Building Automation		
<b>Name:</b>	Fb_Weather		
<b>Type:</b>	Function <input type="checkbox"/>	Function block <input checked="" type="checkbox"/>	Program <input type="checkbox"/>
<b>Library Name:</b>	Building_common.lib		
<b>Applicable to:</b>	All programmable fieldbus controllers		
<b>Input Parameter:</b>			
	<b>Data type:</b>	<b>Comment:</b>	
iInput_Signal	INT	Measured value input	
iLimit1	INT	Parameter value for limit value 1	
iLimit2	INT	Parameter value for limit value 2	
wHyst1	WORD	Parameter value for hysteresis GW1	
wHyst2	WORD	Parameter value for hysteresis GW2	
dwTon_10tel_s	DWORD	Switch-on delay, output signal Value range: 1 – 36000 [0.1s] Default setting = 300	
dwToff_10tel_s	DWORD	Switch-off delay, output signal Value range: 1 – 36000 [0.1s] Default setting = 300	
<b>Feedback Value:</b>			
	<b>Data type:</b>	<b>Comment:</b>	
iOutput_Signal	INT	Measured value output	
xActorLimit1	BOOL	Switching signal at limit value 1	
xActorLimit2	BOOL	Switching signal at limit value 2	
<b>Graphical Display:</b>			
			



## Time Referenced Behavior:

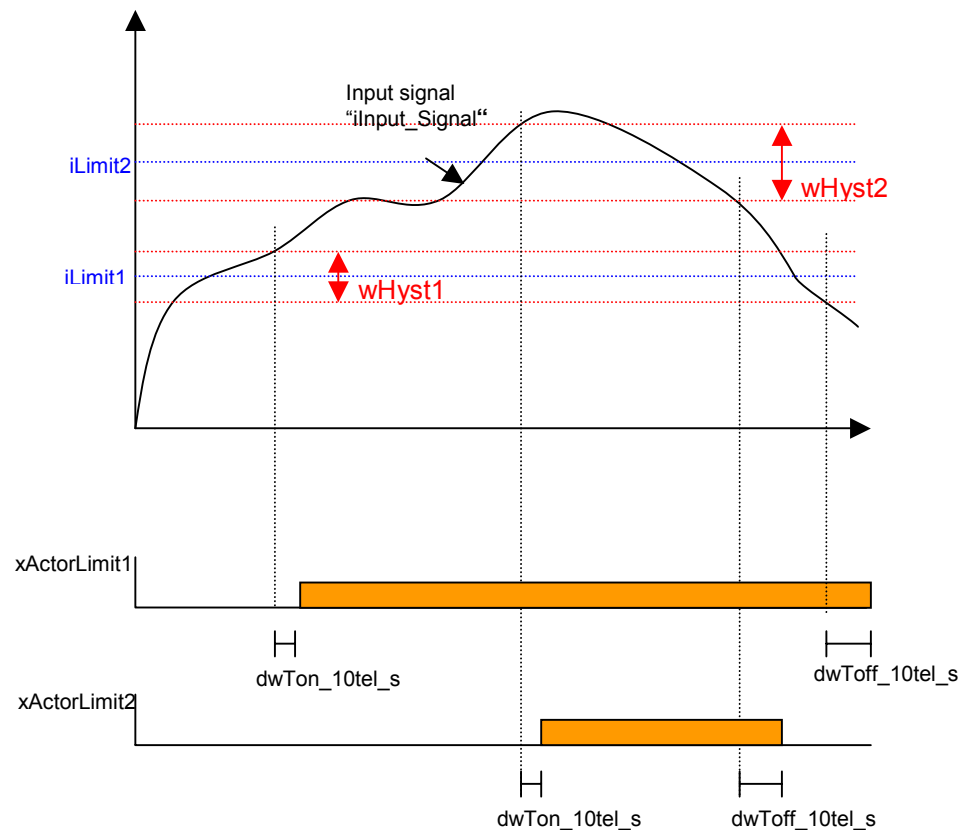

## Function description:

The function block Weather is used to record and transmit analog sensor signals. The measured analog value can be transmitted to the bus as a measuring value. This allows other bus subscribers to process this value, e.g. as a graphical representation.

With the aid of the outputs, weather dependent processes (running up the sunblind, moving in the awning, switching the external lighting etc.) can be controlled. Two limit values ("**iLimit1**", "**iLimit2**") with the attendant hysteresis ("**wHyst1**", "**wHyst2**") can be set for each measured value. If the measured value exceeds the set limit value at input "**iInput\_Signal**", a "1" is sent at the corresponding output ("**xActorLimit1**", "**xActorLimit2**"). If the input value is below the limit value, the signal will be reset. Furthermore, an input and output delay ("**dwTon\_10tel\_s**", "**dwToff\_10tel\_s**") can be parameterized for the output objects to prevent switching commands to be provoked in the event of short-time changes at the measuring signal.

Several of these function blocks can be linked for form a weather station.

## Setting

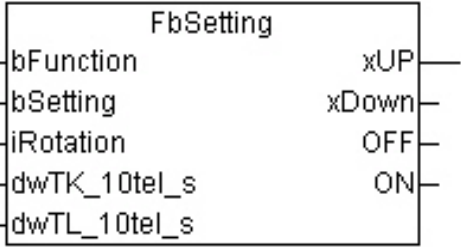
WAGO-I/O-PRO 32 Library Elements		
<b>Category:</b>	Building automation	
<b>Name:</b>	FbSetting	
<b>Type:</b>	Function <input type="checkbox"/>	Function block <input checked="" type="checkbox"/> Program <input type="checkbox"/>
<b>Library Name:</b>	Building_common.lib	
<b>Applicable to:</b>	fieldbus controllers 750-819	
<b>Input Parameter:</b>	<b>Data type:</b>	<b>Comment:</b>
bFunction	BYTE	Input for the element "Function" of the SNVT_setting
bSetting	BYTE	Input for the element "Setting" of the SNVT_setting
iRotation	INT	Input for the element "Rotation" of the SNVT_setting
dwTK_10tel_s	DWORD	Pulse duration of output signal "Short" Range of values: 2 – 100 [0.1s] Preset value = 4
dwTL_10tel_s	DWORD	Pulse duration of output signal "Long" Range of values: 2 – 100 [0.1s] Preset value = 8
<b>Feedback Value:</b>	<b>Data type:</b>	<b>Comment:</b>
xUP	BOOL	Output signal for sunblind Up / Stop
xDOWN	BOOL	Output signal for sunblind Down / Stop
OFF	BOOL	Output is TRUE, if the element "Function" of the SNVT_setting sends "OFF".
ON	BOOL	Output is TRUE, if the element "Function" of the SNVT_setting sends "ON".
<b>Graphical Display:</b>		
		

**Function Description:**

The function block “Setting” transforms the input values of a SNVT\_Setting into short or long output pulses. The length of the output pulses can be set via the inputs “dwTK\_10tel\_s” (short pulse) or “dwTL\_10tel\_s” (long pulse). After evaluation of the signals at the inputs **bFunction**, **bSetting** and **iRotation**, the pulse will be output at **xUP** or **xDOWN**.

In combination with the function block “sunblind” it is thus possible to generate the commands UP / DOWN / STOP as well as slat regulation UP/DOWN.

The times uiTK\_10tel\_s and dwTL\_10tel\_s need to be adjusted to the time setting dwT\_TasKurzIn10telSec of the function block “sunblind”.

The following has to be observed:

**dwTK\_10tel\_s < uiT\_SwitchShortIn10telSec** (FbSunblind:time for short keystroke)

**dwTL\_10tel\_s > uiT\_SwitchShortIn10telSec** (FbSunblind: time for long keystroke)

**Example:**

The bSetting and iRotation values may be disregarded in most applications. Both input values then have to be constant values.

bSetting = 16#00

iRotation = 16#7fff

The bFunction element is set as follows in the Plug In PRIO:

AO

Name: Sunblind.nvi\_SunbFunction

Address: 845

Connected to ...: nviSunblind (SNVT\_setting)

Element: function

Scale: 0 -> 0; 127 -> 127

Use TimeOut:

TimeOut-Value: function: 0;

Default Behavior: Set value







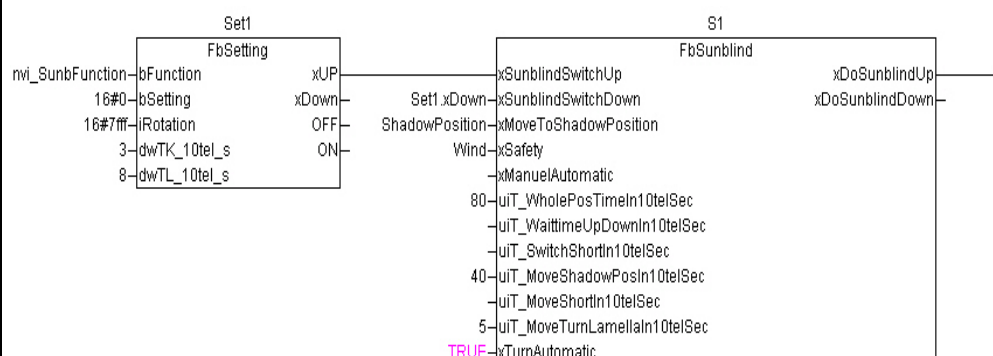

Default Mask:

TimeOut time approx.  
500ms

Example from WAGO I/O PRO:



The table shows the assignment of the output pulses for the different input states of the inputs bFunction, bSetting, and iRotation.

SNVT_Setting			FB output response
Function	Setting	Rotation	
0 (OFF)	00h...FFh	0000h...FFFFh	OFF = TRUE
1 (ON)	00h...FFh	0000h...FFFFh	ON = TRUE
2 (DOWN)	00h	0000h	---
	00h or FFh	0000h < > 4650h	xDOWN = 
	00h...C8h	0000h or 7FFFh	xDOWN = 
	00h or FFh	7FFFh	xDOWN = 
	00h...FFh	< 0000h	---
3 (UP)	00h	0000h	---
	00h or FFh	0000h < > 4650h	xUP = 
	00h...C8h	0000h or 7FFFh	xUP = 
	00h or FFh	7FFFh	xUP = 
	00h...FFh	< 0000h	---
4 (STOP)	00h...FFh	0000h...FFFFh	xDOWN =  or xUP = 
5 (STATE)	00h...FFh	0000h...FFFFh	---

The function **STOP** send a short pulse either via xDOWN or xUP, depending on which command was sent last. If, for example, the last command was an UP command, then a short pulse will also be sent via output xUP in the event of a Stop command.

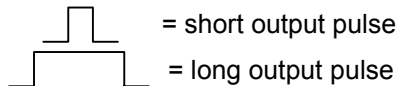

## Operating Time

<b>WAGO-I/O-PRO 32 Library Elements</b>			
<b>Category:</b>	Building Automation		
<b>Name:</b>	FbOperatingTime		
<b>Type:</b>	Function <input type="checkbox"/>	Function block <input checked="" type="checkbox"/>	Program <input type="checkbox"/>
<b>Library Name:</b>	Building_common.lib		
<b>Applicable to:</b>	All programmable fieldbus controllers		
<b>Input Parameter:</b>	<b>Data type:</b>	<b>Comment:</b>	
xEnable	BOOL	The input set "TRUE" will start measurement of operating time.	
xReset	BOOL	The input set "TRUE" will set all output values to "0".	
dwSignalDay	DWORD	Parameter value for the days when a signal is to be output at xSignal. Preset value = 0	
bSignalHour	BYTE	Parameter value for the hours when a signal is to be output at xSignal. Range of values 0 – 23 Preset value = 0	
bSignalMinute	DWORD	Parameter value for the minutes when a signal is to be output at xSignal. Range of values: 0 – 59 Preset value = 0	
xSignalReset	BOOL	The input set "TRUE" will reset the "xSignal" output.	
xPreset	BOOL	A rising edge at this input initializes the counter with preset values.	
dwPresetDay	DWORD	Parameter for the number of days of the preset initial value Preset value = 0	
bPresetHour	BYTE	Parameter for the number of hours of the preset initial value Value range: 0 – 23 Preset value = 0	
bPresetMinute	BYTE	Parameter for the number of minutes of the preset initial value Value range: 0 – 59 Preset value = 0	

Feedback Value:	Data type:	Comment:
rHour_total	REAL	Total operating time.
dwDay	DWORD	Number of days of the total operating time
bHour	BYTE	Number of hours of the total operating time
bMinute	BYTE	Number of minutes of the total operating time
xSignal	BOOL	Output sends a signal that the preset operating time has been reached.
dwNumber	DWORD	Number of activations

**Graphical Display:**

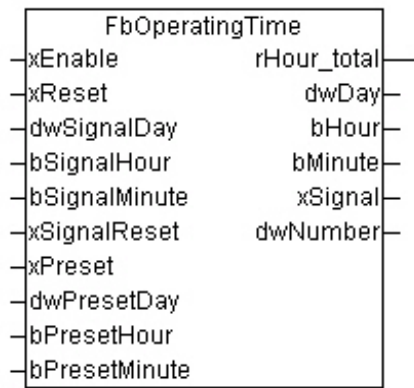

**Function Description:**

If the input “**xEnable**“ is set “TRUE”, the hour meter will be started. The number of activations via the xEnable input will be output at “**dwNumber**“.

If the hour meter reaches the preset values (“**dwSignalDay**“, “**bSignalHour**“, “**bSignalMinute**“) then the “**xSignal**“ output will be activated. This message is used to report necessary maintenance work. The message can be reset by a rising edge at the input “**xSignalReset**“.

The total operating time is indicated via output “**rHour\_total**“.

The outputs “**dwDay**“, “**bHour**“ and “**bMinute**“ indicate the corresponding portion of the total operating time (see example).

A rising edge at the input “**xPreset**“ initializes the counter with the input values “**dwPresetDay**“, “**bPresetHour**“ and “**bPresetMinute**“.

All outputs (except “xSignal”) are reset to 0 via the input “**xReset**“.

**Important note:**

The resolution of the hour meter is 1 minute. It is therefore only reasonable to use this function block if the operating time is to be measured of devices that normally operate over a long period. The longer the operating time, the smaller is the percentage error of the measurement.

**Example:**

**Total operating time = 26h 30m**

⇒ rHour\_total = 26.5

⇒ dwDay = 1

⇒ bHour = 2

⇒ bMinute = 30

**Note:**

This function block uses some residual variables having a **VAR\_RETAIN** declaration.

## Run Duration Control

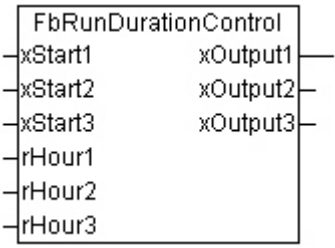
<b>WAGO-I/O-PRO 32 Library Elements</b>		
<b>Category:</b>	Building Automation	
<b>Name:</b>	FbRunDurationControl	
<b>Type:</b>	Function <input type="checkbox"/>	Function block <input checked="" type="checkbox"/> Program <input type="checkbox"/>
<b>Library Name:</b>	Building_common.lib	
<b>Applicable to:</b>	All programmable fieldbus controllers	
<b>Input Parameter:</b>	<b>Data type:</b>	<b>Comment:</b>
xStart1	BOOL	A "TRUE" signal at this input activates one of the three outputs. A "FALSE" signal resets the output.
xStart2	BOOL	A "TRUE" signal at this input activates one of the three outputs. A "FALSE" signal resets the output.
xStart3	BOOL	A "TRUE" signal at this input activates one of the three outputs. A "FALSE" signal resets the output.
rHour1	REAL	Input value of the measured operating time for output1
rHour2	REAL	Input value of the measured operating time for output2
rHour3	REAL	Input value of the measured operating time for output3
<b>Feedback Value:</b>	<b>Data type:</b>	<b>Comment:</b>
xOutput_1	BOOL	Output Signal 1
xOutput_2	BOOL	Output Signal 2
xOutput_3	BOOL	Output Signal 3
<b>Graphical Display:</b>		
		



**Function Description:**

This function block controls activation and deactivation of the three outputs “**xOutput(1-3)**” depending on their hours of operation.

If a “TRUE” signal on one of the three inputs “**xStart(1-3)**” gives the command to activate one output, then the output having the shortest operating period will be set to “TRUE”.

If another input xStart(1-3) is set to “TRUE”, the output with the next longer operating period will be activated.

Deactivation of the outputs will also be made depending on operating periods. A reset of a start signal will result in deactivation of the output with the longest operating period.

The function block is provided with the operating periods of the outputs via the inputs “**rHour(1-3)**”. The operating period can be determined using for example the function block FbOperatingTime.

A typical application for this function block is the use in strip lighting (switching on / off 1/3, 2/3, or 3/3).

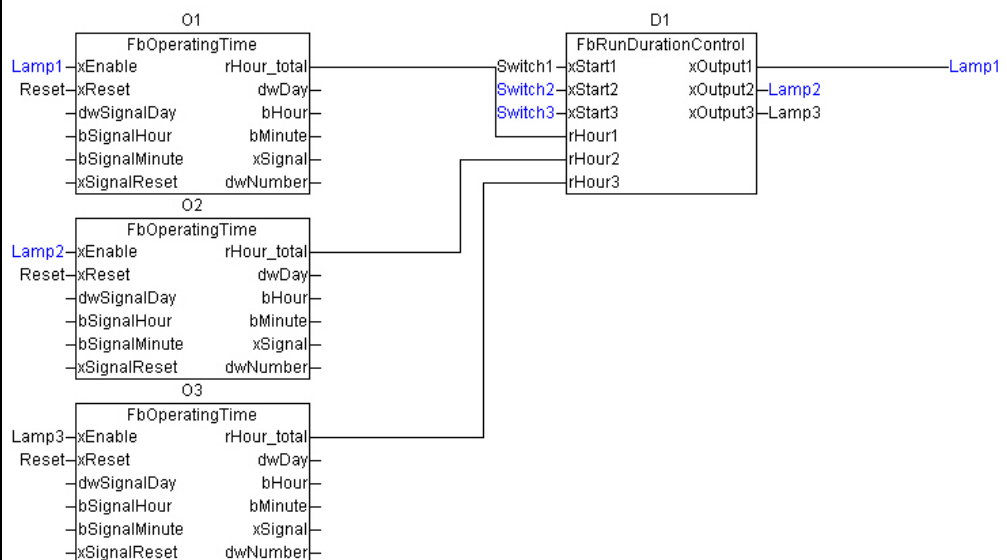
**Example of application:**

# Time

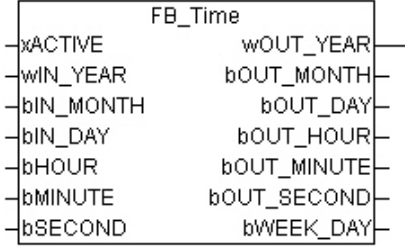
<b>WAGO-I/O-PRO 32 Library Elements</b>		
<b>Category:</b>	Building Automation	
<b>Name:</b>	FbTime	
<b>Type:</b>	Function <input type="checkbox"/>	Function block <input checked="" type="checkbox"/> Program <input type="checkbox"/>
<b>Library Name:</b>	Building_common.lib	
<b>Applicable to:</b>	All programmable fieldbus controllers	
<b>Input Parameter:</b>		
<b>Data type:</b>	<b>Comment:</b>	
xACTIVE	BOOL	A "TRUE" signal starts the clock function.
wIN_YEAR	WORD	Input signal year
bIN_MONTH	BYTE	Input signal month [1 – 12]
bIN_DAY	BYTE	Input signal day [1 – 31]
bHour	BYTE	Input signal hour [0 – 23]
bMINUTE	BYTE	Input signal minute [0 – 59]
bSECOND	BYTE	Input signal second [0 – 59]
<b>Feedback Value:</b>		
<b>Data type:</b>	<b>Comment:</b>	
wOUT_YEAR	WORD	Output signal year
bOUT_MONTH	BYTE	Output signal month
bOUT_DAY	BYTE	Output signal day
bOUT_HOUR	BYTE	Output signal hour
bOUT_MINUTE	BYTE	Output signal minute
bOUT_SECOND	BYTE	Output signal second
bWEEK_DAY	BYTE	Weekday value: 1 = Monday 2 = Tuesday 3 = Wednesday 4 = Thursday 5 = Friday 6 = Saturday 7 = Sunday
<b>Graphical Display:</b>		
		

**Function Description:**

The programmable WAGO controllers do not incorporate a hardware real-time clock. The function block FbTime allows the simulation of a clock. There is a time discrepancy of approx. 10 s per day. It is therefore necessary to synchronize the function block with an external real-time clock (we recommend to synchronize once a day). Synchronization is done via the inputs **"bIN\_YEAR"**, **"bIN\_MONTH"**, **"bIN\_DAY"**, **"bIN\_HOUR"**, **"bIN\_MINUTE"**, and **"bIN\_SECOND"**.

If there is a value change at the input, **"bIN\_HOUR"**, **"bIN\_MINUTE"** or **"bIN\_SECOND"**, then the corresponding outputs **"bOUT\_HOUR"**, **"bOUT\_MINUTE"** or **"bOUT\_SECOND"** will be initialized with the new values. This is also the case with the outputs **"bOUT\_YEAR"**, **"bOUT\_MONTH"**, and **"bOUT\_DAY"**.

If there is no input value change, time keeps running at the output, simulating a real-time clock. At midnight the output value **bOUT\_DAY** is automatically adjusted to the next day. Leap years are taken into account.

At midnight on the last day of the month the output value **bOUT\_Month** is also adjusted to the following month. A turn of the year, too, is processed by the function block.

In consideration of the output values **bOUT\_YEAR**, **bOUT\_MONTH**, and **bOUT\_DAY** the weekday (Monday .. Sunday = 1 .. 7) is calculated and output at **"bWEEK\_DAY"**.

If the input signal **"xACTIVE"** is set to **"TRUE"**, then the outputs **bOUT\_HOUR**, **bOUT\_MINUTE**, and **bOUT\_SECOND** will be initialized with the appropriate input values. With a **"FALSE"** signal all outputs have the value zero.

**Notes:**

- The calculation of the weekday in the simulation mode of the WAGO I/O PRO is incorrect. However, the calculation of the controller (except 750-841) is correct.
- This function block uses some residual variables having a **VAR\_RETAIN** declaration.

## Time Switch

<b>WAGO-I/O-PRO 32 Library Elements</b>		
<b>Category:</b>	Building Automation	
<b>Name:</b>	FbTimeSwitch	
<b>Type:</b>	Function <input type="checkbox"/>	Function block <input checked="" type="checkbox"/> Program <input type="checkbox"/>
<b>Library Name:</b>	Building_common.lib	
<b>Applicable to:</b>	All programmable fieldbus controllers	
<b>Input Parameter:</b>	<b>Data type:</b>	<b>Comment:</b>
bWEEK_DAY	BYTE	Input signal of the current weekday. 1 = Monday 2 = Tuesday 3 = Wednesday 4 = Thursday 5 = Friday 6 = Saturday 7 = Sunday
bInputHour	WORD	Input signal hour
bInputMinute	BYTE	Input signal minute
bOnHour	BYTE	Operating time hour
bOnMinute	BYTE	Operating time minute
bOffHour	BYTE	OFF-time hour
bOffMinute	BYTE	OFF-time minute
xMonday_1	BOOL	Activates / deactivates switching command on Monday Preset value = TRUE
xTuesday_2	BOOL	Activates / deactivates switching command on Tuesday Preset value = TRUE
xWednesday_3	BOOL	Activates / deactivates switching command on Wednesday Preset value = TRUE
xThursday_4	BOOL	Activates / deactivates switching command on Thursday Preset value = TRUE
xFriday_5	BOOL	Activates / deactivates switching command on Friday Preset value = TRUE
xSaturday_6	BOOL	Activates / deactivates switching command on Saturday Preset value = TRUE
xSunday_7	BOOL	Activates / deactivates switching command on Sunday Preset value = TRUE
<b>Feedback Value:</b>	<b>Data type:</b>	<b>Comment:</b>
xOutput	BOOL	Output switching signal

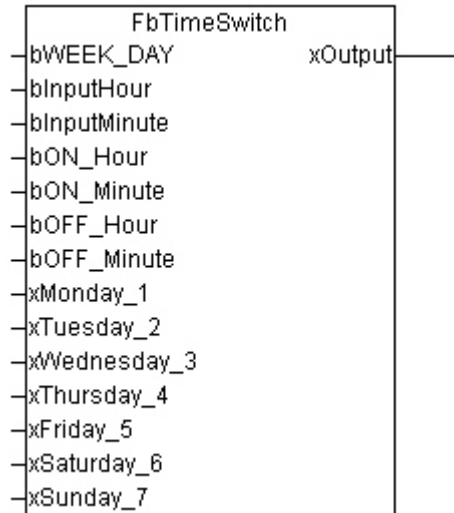
**Graphical Display:****Function Description:**

The function block switches the output xOutput ON/OFF, depending on daytime and weekday. The values of the current weekday and the current time must be provided to the function block at the inputs “**wWEEK\_DAY**“, “**bInputHour**“, and “**bInputMinute**“.

The operating time is predefined at the inputs “**bON\_Hour**“ or “**bON\_Minute**“, the OFF-time is predefined at the inputs “**bOffHour**“ or “**bOFF\_Minute**“. If the time-based switching command shall not be executed on certain weekdays, the appropriate input for that weekday has to be set to FALSE (e.g. xSaturday\_6 = FALSE).

## Random Function

WAGO-I/O-PRO 32 Library Elements		
<b>Category:</b>	Building Automation	
<b>Name:</b>	FbRandom	
<b>Type:</b>	Function <input type="checkbox"/>	Function block <input checked="" type="checkbox"/> Program <input type="checkbox"/>
<b>Library Name:</b>	Building_common.lib	
<b>Applicable to:</b>	All programmable fieldbus controllers	
<b>Input Parameter:</b>	<b>Data type:</b>	<b>Comment:</b>
xStart	BOOL	A "TRUE" signal at this input will start the Random function (see examples below)
dwT_In10telMin	DWORD	Period during which one of the three outputs is switched. The period has a random deviation of $\pm 15$ minutes Range of values: 20 – 3000 [0.1 min] Preset value = 100
bOutputNo	BYTE	Number of activated outputs Range of values: 1-3
<b>Feedback value:</b>	<b>Data type:</b>	<b>Comment:</b>
xOutput_1	BOOL	Output signal 1
xOutput_2	BOOL	Output signal 2
xOutput_3	BOOL	Output signal 3
<b>Graphical display:</b>		
		

**Function description:**

A "TRUE" signal at the input "**xStart**" will start the change-over of the outputs "**xOutput\_1 – 3**" in a random order.

The time between change-overs is predefined via the input "**dwT\_In10telMin**". A period of  $\pm 15$  minutes is randomly added to the time constant. The minimum interval between change-overs is 2 minutes. If the input "xStart" is set to "FALSE", all outputs "xOutput\_1 – 3" are reset.

The input value "**bOutputNo**" predefines the number of outputs that are used for the following examples.

**Examples:**

- $dwT\_In10telMin = 200$  (20 minutes)  $\Rightarrow$  change-over at one of the three outputs within 5 - 35 minutes.
- $dwT\_In10telMin = 50$  (5 minutes)  $\Rightarrow$  change-over at one of the three outputs within 2-20 minutes.

## UnpackSwitch

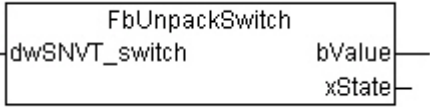
<b>WAGO-I/O-PRO 32 Library Elements</b>		
<b>Category:</b>	Building Automation	
<b>Name:</b>	FbUnpackSwitch	
<b>Type:</b>	Function <input type="checkbox"/>	Function block <input checked="" type="checkbox"/> Program <input type="checkbox"/>
<b>Library Name:</b>	Building_common.lib	
<b>Applicable to:</b>	Feldbus-Controller 750-819	
<b>Input Parameter:</b>	<b>Data type:</b>	<b>Comment:</b>
dwSNVT_switch	DWORD	Input signal of the configuration variable of the SNVT_switch type
<b>Feedback Value:</b>	<b>Data type:</b>	<b>Comment:</b>
bValue	BYTE	Output value for the element "Value" of the SNVT_switch
xState	BOOL	Output value for the element "State" of the SNVT_switch
<b>Graphical Display:</b>		
		
<b>Function Description:</b>		
<p>The function block "UnpackSwitch" is used when a configuration variable (Configuration Property) of the SNVT_switch type from the LNS Plug-In PRIO (Neuron chip) is passed to WAGO I/O PRO (C165). The configuration values are passed via a Retain Variable of the DWORD data type. In order to access the structure elements of the SNVT_switch variable it is necessary to unpack them. The function block "UnpackSwitch" converts the input signal dwSNVT_switch into the two elements bValue (dimmer) and xState (switching state).</p>		

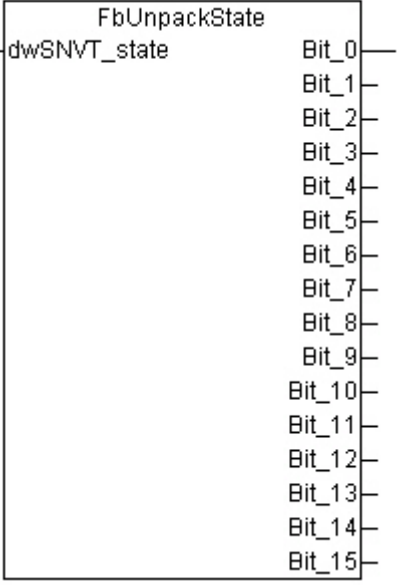

## UnpackState

<b>WAGO-I/O-PRO 32 Library Elements</b>		
<b>Category:</b>	Building Automation	
<b>Name:</b>	FbUnpackState	
<b>Type:</b>	Function <input type="checkbox"/>	Function block <input checked="" type="checkbox"/> Program <input type="checkbox"/>
<b>Library Name:</b>	Building_common.lib	
<b>Applicable to:</b>	Feldbus-Controller 750-819	
<b>Input Parameter:</b>		
	<b>Data type:</b>	<b>Comment:</b>
dwSNVT_state	DWORD	Input signal of the configuration variable SNVT_state
<b>Feedback Value:</b>		
	<b>Data type:</b>	<b>Comment:</b>
Bit_0	BOOL	Output value for the element "Bit0" of the SNVT_state
...	...	...
...	...	...
...	...	...
Bit_15	BOOL	Output value for the element "Bit15" of the SNVT_state
<b>Graphical Display:</b>		
		
<b>Function Description:</b>		
<p>The function block "UnpackState" is used when a configuration variable (Configuration Property) of the SNVT_state type from the LNS Plug-In PRIO (Neuron chip) is passed to WAGO I/O PRO (C165). The configuration values are passed via a Retain Variable of the DWORD data type. In order to access the structure elements of the SNVT_state variable it is necessary to unpack them. The function block "UnpackState" converts the input signal dwSNVT_state into the 16 elements Bit_0 to Bit_15.</p>		

## UnpackScene

<b>WAGO-I/O-PRO 32 Library Elements</b>		
<b>Category:</b>	Building Automation	
<b>Name:</b>	FbUnpackScene	
<b>Type:</b>	Function <input type="checkbox"/>	Function block <input checked="" type="checkbox"/> Program <input type="checkbox"/>
<b>Library Name:</b>	Building_common.lib	
<b>Applicable to:</b>	Feldbus-Controller 750-819	
<b>Input Parameter:</b>	<b>Data type:</b>	<b>Comment:</b>
dwSNVT_scene	DWORD	Input signal of the configuration variable SNVT_scene
<b>Feedback Value:</b>	<b>Data type:</b>	<b>Comment:</b>
bfunction	BYTE	Output value for the element "Function" of the SNVT_scene
bScene_number	BYTE	Output value for the element "Scene_number" of the SNVT_scene
<b>Graphical Display:</b>		
		
<b>Function Description:</b>		
<p>The function block "UnpackScene" is used when a configuration variable (Configuration Property) of the SNVT_scene type from the LNS Plug-In PRIO (Neuron chip) is passed to WAGO I/O PRO (C165). The configuration values are passed via a Retain Variable of the DWORD data type. In order to access the structure elements of the SNVT_scene variable it is necessary to unpack them. The function block "UnpackScene" converts the input signal dwSNVT_scene into the two elements bfunction and bScene_number.</p>		

## UnpackSetting

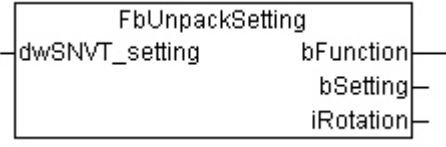
<b>WAGO-I/O-PRO 32 Library Elements</b>		
<b>Category:</b>	Building Automation	
<b>Name:</b>	FbUnpackSetting	
<b>Type:</b>	Function <input type="checkbox"/>	Function block <input checked="" type="checkbox"/> Program <input type="checkbox"/>
<b>Library Name:</b>	Building_common.lib	
<b>Applicable to:</b>	Feldbus-Controller 750-819	
<b>Input Parameter:</b>	<b>Data type:</b>	<b>Comment:</b>
dwSNVT_setting	DWORD	Input signal of the configuration variable SNVT_setting
<b>Feedback Value:</b>	<b>Data type:</b>	<b>Comment:</b>
bFunction	BYTE	Output value for the element "Function" of the SNVT_setting
bSetting	BYTE	Output value for the element "Setting" of the SNVT_setting
iRotation	INT	Output value for the element "Rotation" of the SNVT_setting
<b>Graphical Display:</b>		
		
<b>Function Description:</b>		
<p>The function block "UnpackSetting" is used when a configuration variable (Configuration Property) of the SNVT_setting type from the LNS Plug-In PRIO (Neuron chip) is passed to WAGO I/O PRO (C165). The configuration values are passed via a Retain Variable of the DWORD data type. In order to access the structure elements of the SNVT_setting variable it is necessary to unpack them. The function block "UnpackSetting" converts the input signal dwSNVT_setting into the three elements bFunction, bSetting and iRotation.</p>		

## SCPT\_lev\_percent

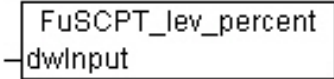
<b>WAGO-I/O-PRO 32 Library Elements</b>		
<b>Category:</b>	Building Automation	
<b>Name:</b>	FuSCPT_lev_percent	
<b>Typ:</b>	Function <input checked="" type="checkbox"/>	Function block <input type="checkbox"/> Program <input type="checkbox"/>
<b>Library Name:</b>	Building_common.lib	
<b>Applicable to:</b>	Feldbus-Controller 750-819	
<b>Input Parameter:</b>	<b>Data type:</b>	<b>Comment:</b>
dwSCPT_lev_percent	DWORD	Input signal of the configuration variable of type SCPT_lev_percent
<b>Feedback Value:</b>	<b>Data type:</b>	<b>Comment:</b>
FuSCPT_lev_percent	REAL	Output value SCPT_lev_percent value range -163.84 % - 163.83%
<b>Graphical Display:</b>		
		
<b>Function Description:</b>		
<p>The function FuSCPT_lev_percent is used if a configuration variable (configuration property) of type SNVT_lev_percent is to be transferred from the LNS Plug-In PRIO (Neuron Chip) to the WAGO I/O PRO (C165). The configuration values are usually transferred via a retain variable of data type DWORD. To also reach the negative values of the variables SNVT_lev_percent, a conversion of the values is therefore necessary. The function FuSCPT_lev_percent converts the input signal of the data type DWORD into an output variable of type REAL.</p>		

## SCPT\_temp

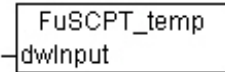
<b>WAGO-I/O-PRO 32 Library Elements</b>		
<b>Category:</b>	Building Automation	
<b>Name:</b>	FuSCPT_temp	
<b>Typ:</b>	Function <input checked="" type="checkbox"/>	Function block <input type="checkbox"/> Program <input type="checkbox"/>
<b>Library Name:</b>	Building_common.lib	
<b>Applicable to:</b>	Feldbus-Controller 750-819	
<b>Input Parameter:</b>	<b>Data type:</b>	<b>Comment:</b>
dwSCPT_temp	DWORD	Input signal of the configuration variable of type SCPT_temp
<b>Feedback Value:</b>	<b>Data type:</b>	<b>Comment:</b>
FuSCPT_temp	DINT	Output value SCPT_temp Value range -2740 – 62795 [0.1°C]
<b>Graphical Display:</b>		
		
<b>Function Description:</b>		
<p>The function FuSCPT_temp is used if a configuration variable (configuration property) of type SNVT_temp is to be transferred from the LNS Plug-In PRIO (Neuron Chip) to the WAGO I/O PRO (C165). The configuration values are usually transferred via a retain variable of data type DWORD. To also reach the negative values of the variables SNVT_temp, a conversion of the values is therefore necessary. The function FuSCPT_temp converts the input signal of the data type DWORD into an output variable of type DINT.</p>		

## SCPT\_temp\_p

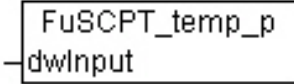
<b>WAGO-I/O-PRO 32 Library Elements</b>		
<b>Category:</b>	Building Automation	
<b>Name:</b>	FuSCPT_temp_p	
<b>Typ:</b>	Function <input checked="" type="checkbox"/>	Function block <input type="checkbox"/> Program <input type="checkbox"/>
<b>Library Name:</b>	Building_common.lib	
<b>Applicable to:</b>	Feldbus-Controller 750-819	
<b>Input Parameter:</b>	<b>Data type:</b>	<b>Comment:</b>
dwSCPT_temp_p	DWORD	Input signal of the configuration variable of type SCPT_temp_p
<b>Feedback Value:</b>	<b>Data type:</b>	<b>Comment:</b>
FuSCPT_temp_p	INT	Output value SCPT_temp_p Value range -27317- 32766 [0.01°C]
<b>Graphical Display:</b>		
		
<b>Function Description:</b>		
<p>The function FuSCPT_temp_p is used if a configuration variable (configuration property) of type SNVT_temp_p is to be transferred from the LNS Plug-In PRIO (Neuron Chip) to the WAGO I/O PRO (C165). The configuration values are usually transferred via a retain variable of data type DWORD. To also reach the negative values of the variables SNVT_temp_p, a conversion of the values is therefore necessary. The function FuSCPT_temp_p converts the input signal of the data type DWORD into an output variable of type INT.</p>		

## Constant light control for 0 – 10 V applications

WAGO-I/O-PRO 32 Library Elements		
<b>Category:</b>	Building Automation	
<b>Name:</b>	FbConstantLightControl	
<b>Type:</b>	Function <input type="checkbox"/>	Function block <input checked="" type="checkbox"/> Program <input type="checkbox"/>
<b>Library name:</b>	Building_common.lib	
<b>Applicable to:</b>	Programmable fieldbus controllers	
<b>Input parameter:</b>	<b>Data type:</b>	<b>Comment:</b>
xToggle	BOOL	Input with a change over function
wBasicSetpValue	WORD	Basic setpoint value for light intensity in [lux]
wRealValue	WORD	Input signal of the light sensor Value range: 0 – 32767
wMaxMeasuredValueSensor	WORD	Maximum measured value of the light sensor in [lux] Default setting = 2000
xOn_and_Brighter	BOOL	The lighting is switched on by pushing the button briefly. The lighting is dimmed brighter by pushing the button longer at xSetpValueShifting = TRUE
xOff_and_Darker	BOOL	The lighting is switched off by pushing the button briefly. The lighting is dimmed lower by pushing the button longer at xSetpValueShifting = TRUE
xCentralOn	BOOL	The lighting is switched on via the central function.
xCentralOff	BOOL	The lighting is switched off via the central function.
xPresenceDetector	BOOL	Switching signal of the presence detector. The lighting is switched off by a falling edge.
xSetpValueShifting	BOOL	TRUE= The setpoint value can be shifted up or down Otherwise wBasicSetpValue is valid
xMemo	BOOL	Memo function ON or OFF

dwButtonShort_10tel_s	DWORD	Time for pushing the button briefly Value range: 3 – 100 [0,1 s] Default setting = 5
bMinDimmingLevel	BYTE	Minimum dimming level of the lighting Value range: 6 – 200 (3 – 100 %) Default setting = 10 (5 %)
bMaxDimmingLevel	BYTE	Maximum dimming level of the lighting Value range: 6 – 200 (3 – 100 %) Default setting = 200 (100 %)
wDimmingSpeed	WORD	Duration between min. dimming level and max. dimming level. Value range: 10 – 1000 [0,1 s] Default setting = 100
dwSwitch_OffDelay	DWORD	Switch-off delay of the lighting at minimum dimming level. The lighting remains on, when the switch-off delay is 0. Value range: 1 - 30 [min] Default setting = 0
rCalibration	REAL	Input used to calibrate the light sensor. Default setting = 5
bAdaptation_in_Percent	BYTE	Input used to adapt the calibration value to the daylight. Value range: 0 - 100 % Default setting = 70
<b>Input/output parameter:</b>		
wSetpValue	WORD	Setpoint light intensity for the controller in [lux]
<b>Feedback value:</b>		
xSwitching	BOOL	Output used to switch the lamps
wAO_DimmingLevel	WORD	Dimming level for the analogue output module 0 – 10 V Value range: 0 – 32767
bNVO_DimmingLevel	BYTE	Dimming level for LON via “NVO” Value range: 0 – 200

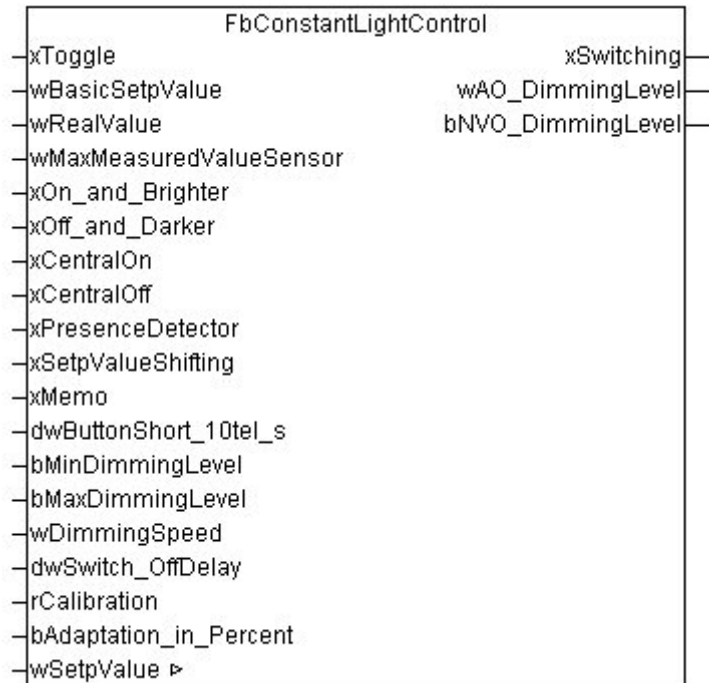

**Graphical display:****Function description:**

The function block enables constant light to be controlled automatically in connection with a light sensor. The current brightness value is polled via the "**wRealValue**" input. Adapting the measured value "**wRealValue**" to the measuring range of the light sensor is done via the "**wMaxMeasuredValueSensor**" input. The determined real value is compared with the setpoint value "**wSetpValue**". The lighting is dimmed if these two values differ from each other.

By pushing the input buttons "**xOn\_and\_Brighter**" or "**xOff\_and\_Darker**" longer, the setpoint light intensity at input "**wSetpValue**" can be shifted up or down. This is only possible when the input signal "**xSetpValueShifting**" is TRUE.

The lighting is switched on or off by briefly pushing (briefer than the "**dwButtonShort\_10tel\_s**" time) the input buttons "**xOn\_and\_Brighter**" or "**xOff\_and\_Darker**". When switching on, the light intensity is adjusted to the setpoint value "**wSetpValue**".

If the input "**xMemo**" is TRUE, the previously adjusted setpoint value "**wSetpValue**" will be memorised after switching off and recalled when switching on again.

If this memory function is not required, the signal at input "**xMemo**" is set to FALSE. In this case, the value "**wBasicSetpValue**" will be set for "**wSetpValue**", when switching the lighting on.

Using the inputs **“xCentralOn”** and **“xCentralOff”**, the output of the function block can be switched ON or OFF via a central command.

With a presence dependent constant light control, the switching contact of the presence detector is connected to the input **“xPresenceDetector”**. The lighting is switched off by a falling edge of the presence detector.

The maximum and minimum dimming level is set via inputs **“bMaxDimmingLevel”** and **“bMinDimmingLevel”**.

The time in which the brightness signal changes from **“bMinDimmingLevel”** to **“bMaxDimmingLevel”** is set using the input **“wDimmingSpeed”**. This time only refers to the setpoint value shifting of inputs **“xEin\_und\_Heller”** and **“xOff\_and\_Darker”**.

The time after which the lighting will switch off at minimum dimming position is set using the input **“dwSwitch\_OffDelay”**. The time is restarted if the dimming position changes during this time period. If the value is ZERO at input **“dwSwitch-offDelay”**, the lighting won't switch off automatically.

Using the parameters **“rCalibration”** and **“bAdaptation\_in\_Percent”**, the measured value of the ceiling-mounted light sensor is compared with the light intensity in the workplace.

Switching on the lighting is done via the **“xSwitching”** output and setting the dimming level for the analogue output module 0 – 10 V is performed using the output **“wAO\_DimmingLevel”**. At output **“bNVO\_DimmingLevel”**, the dimming level will alternatively be set in a range of values from 0 to 200. This range of values complies with the scaling of the SNVT\_Switch LON network variables.

**Attention: The inputs “rCalibration” and “bAdaptation\_in\_Percent” should be defined as constants and “wSetpValue” as a retained variable.**

#### Calibration requirements:

- The source of light to be measured must be switched on about 20 minutes before measuring, so that the lamps can operate at their full potential.
- The setpoint light intensity is to be measured on the work surface using a luxmeter that has a good fit to the  $V(\lambda)$  curve.
- The calibration cannot be performed until the room has been completely furnished since the measured values of the lightsensor depend on the reflection properties of the room.
- rCalibration = 5
- bAdaptation\_in\_Percent = 70

Two measurements are required for calibrating the light sensor. For both measurements, the luxmeter is placed on the work surface where the desired light intensity must be reached.

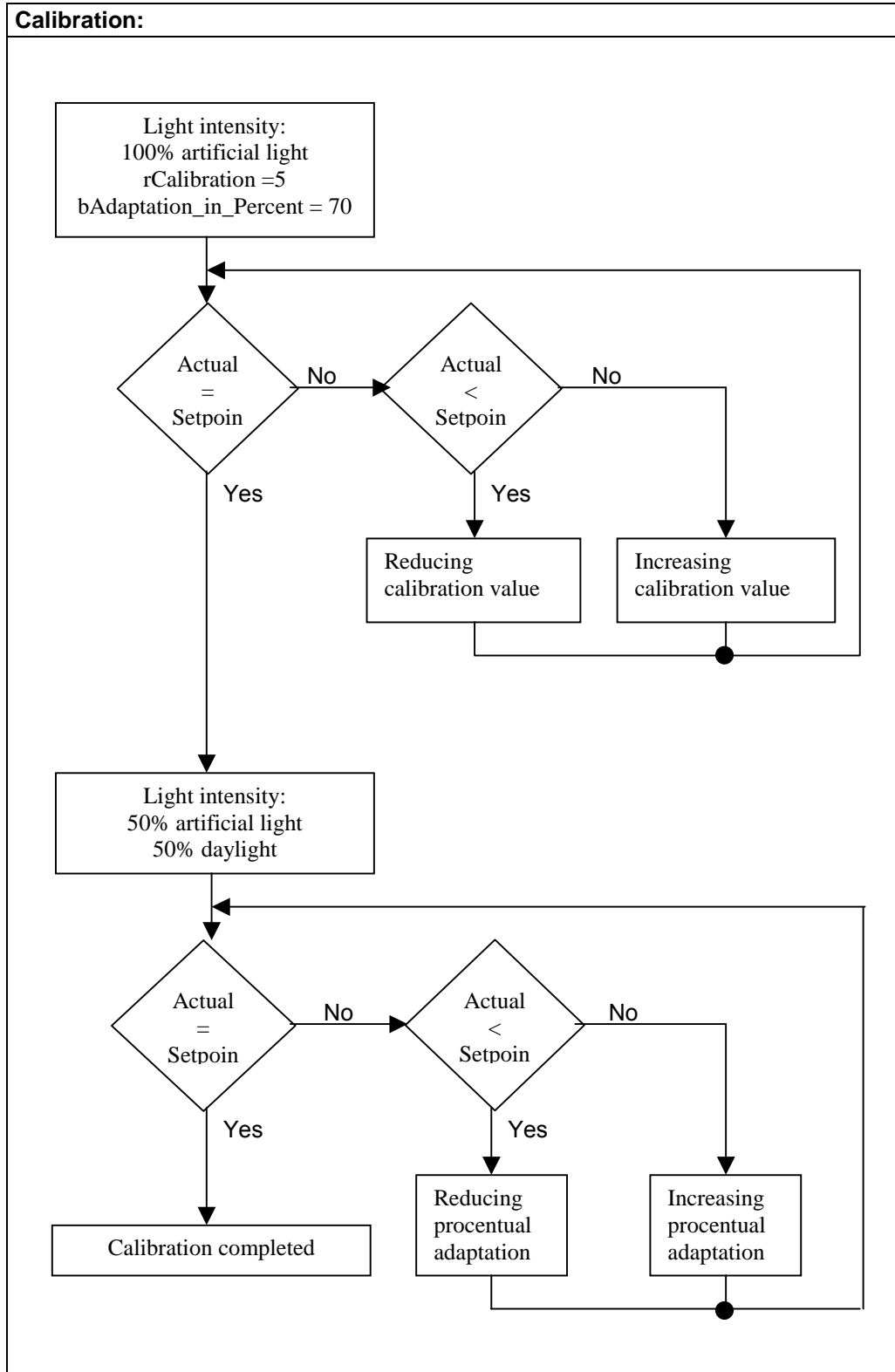

The first measurement is performed in a darkened room using pure artificial light. The calibration value is determined as follows:

- If the light intensity in the workplace is higher than the setpoint light intensity, the calibration value must be increased until the desired light intensity is reached.
- If the light intensity in the workplace is lower than the setpoint light intensity, the calibration value must be decreased until the desired light intensity is reached.

For safety reasons, the light intensity measured by the luxmeter should be about 10 % higher than the desired setpoint light intensity.

The second calibration measurement is required in order to determine the procentual adaptation of the calibration value.

This measurement is performed in a semi-darkened room with residual artificial light.

The second measurement is performed as follows:

- If the light intensity in the workplace is lower than the setpoint light intensity, the percentage of the adaptation must be increased until the desired light intensity is reached.
- If the light intensity in the workplace is higher than the desired light intensity, the percentage of the adaptation must be decreased until the desired light intensity is reached.

If the procentual adaptation of the calibration value is performed in a semi-darkened room, the lowest possible offset is achieved depending on the part of daylight or artificial light. The actual value of the light intensity can still be lower than the setpoint light intensity.





WAGO Kontakttechnik GmbH  
Postfach 2880 • D-32385 Minden  
Hansastraße 27 • D-32423 Minden  
Telefon: 05 71/8 87 – 0  
Telefax: 05 71/8 87 – 1 69  
E-Mail: [info@wago.com](mailto:info@wago.com)

Internet: <http://www.wago.com>

---