

LUM HALOSTAR®

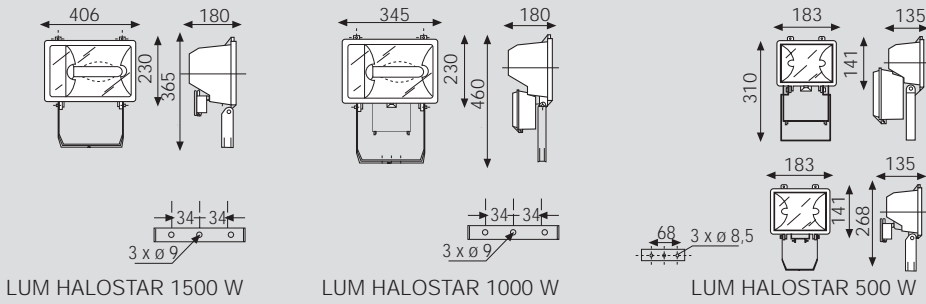

LIVRÉ SANS LAMPE



Désignation



LUM HALOSTAR®

LUM HALOSTAR® 500 blanc	114,2	500	HALOLINE	⊕,IK08,IP55,650°C	Blanc	-	1,5	12	353111
LUM HALOSTAR® 500 noir	114,2	500	HALOLINE	⊕,IK08,IP55,650°C	Noir	-	1,5	12	385112
LUM HALOSTAR® 1000 blanc	185,7	1000	HALOLINE	⊕,IK08,IP55,650°C	Blanc	-	3,2	1	353098
LUM HALOSTAR® 1500 blanc	250,7	1500	HALOLINE	⊕,IK08,IP55,650°C	Blanc	-	3,6	1	385099

ACCESSOIRES - LUM HALOSTAR®

Grille Protection LUM HALOSTAR® 500								1	2	907413
Grille Protection LUM HALOSTAR® 1000								1	8	907437
Grille Protection LUM HALOSTAR® 1500								1	8	907550
Grille de défilement LUM HALOSTAR® 500								2	2	906461
Grille de défilement LUM HALOSTAR® 1000								2	2	906485
Grille de défilement LUM HALOSTAR® 1500								2	2	906522
Visière HALOSTAR® 500								3	1	906447

LUM HALOSTAR®

Projecteur étanche halogène, à fixer.

- Corps et cadre en fonte d'aluminium traité anti-corrosion, avec joint silicone.
- Vitre de protection en verre trempé.
- Réflecteur en aluminium poli martelé.
- Etrier de fixation en acier anodisé avec écrous d'inclinaison latéraux 45° V 90°.
- Passage d'alimentation presse-étoupe Ø 13 avec serre-câble.

Bornier : 2 bornes à vis + terre séparée

Labels & agréments :

Accessoires

- 1 : Grille de protection anti-choc à fils, en acier trempé époxy traité anti-corrosion.
- 2 : Grille de défilement anti-éblouissement à lamelles, en acier trempé époxy traité anti-corrosion.
- 3 : Visière anti-éblouissement, en tôle d'acier électro-zingué (anti-corrosion)

