



GE Interlogix

ARITECH

EV435-AD Series Detector Installation Manual

GB

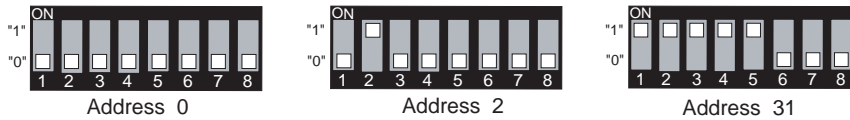
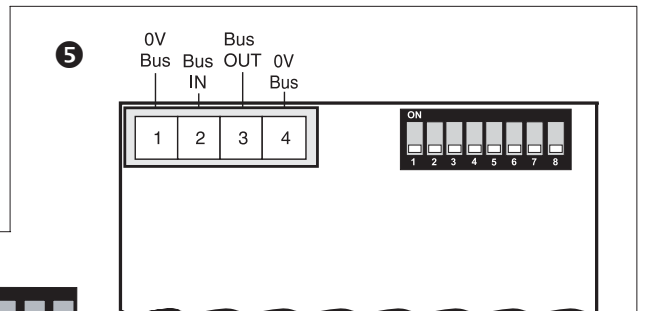
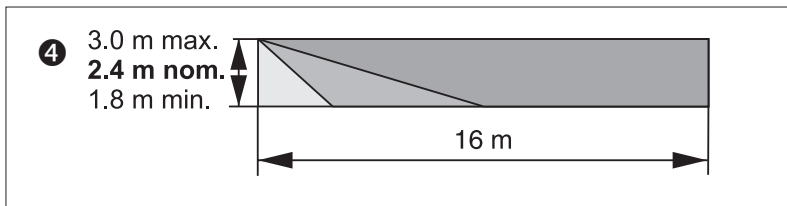
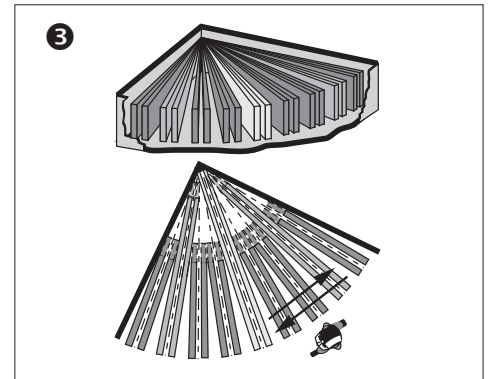
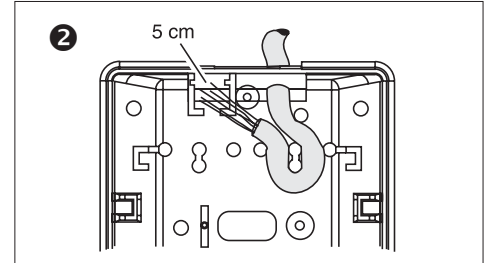
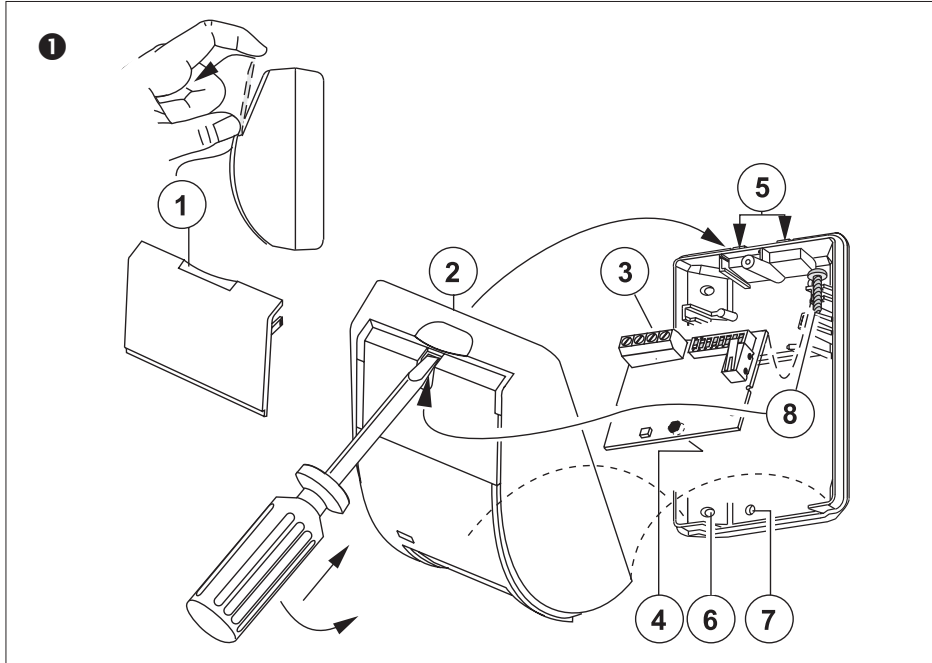

Address	Setting	Address	Setting	Address	Setting	Address	Setting
0	00000000	8	00010000	16	00001000	24	00011000
1	10000000	9	10010000	17	10001000	25	10011000
2	01000000	10	01010000	18	01001000	26	01011000
3	11000000	11	11010000	19	11001000	27	11011000
4	00100000	12	00110000	20	00101000	28	00111000
5	10100000	13	10110000	21	10101000	29	10111000
6	01100000	14	01110000	22	01101000	30	01111000
7	11100000	15	11110000	23	11101000	31	11111000 ("1" = ON)

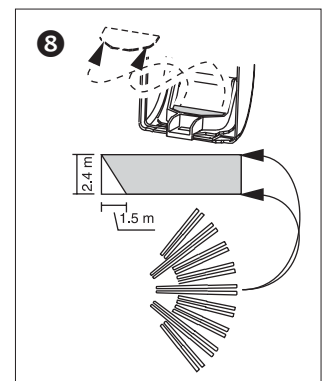
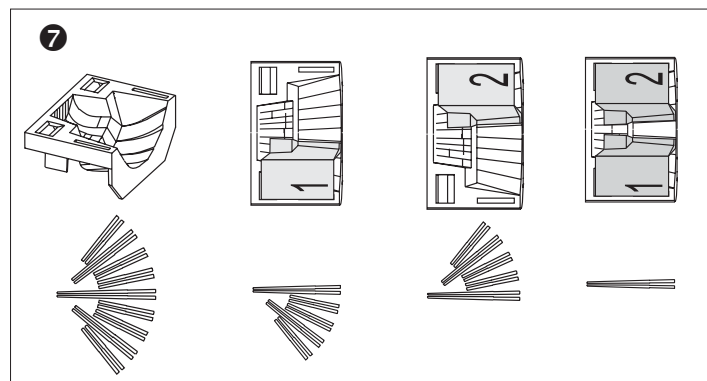
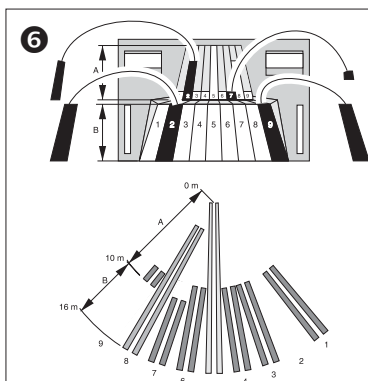

1. Introduction

The EV435-AD is a fully integrated anti-mask detector for the Point ID bus. The housing is protected with a cover tamper. A pry-off tamper is available but not included.

The detector can be manually addressed from addresses 0 to 255 with the on board DIP switch. Switch 1 is the LSB.

2. Device Category

The EV435-AD is of the device category PIR type 3 and will be automatically recognised after learning the device into the ATS1290 DGP. For more details about device categories and types, refer to the ATS1290 manual.

3. Installing the Detector

Install the detector so that the expected movement of an intruder will be across the fields of view. This is the direction best detected by PIR detectors (fig. 3).

As with all PIRs the following false alarm sources should be avoided:

- Direct sunlight on the detector.
- Heat sources in a field of view (heaters, radiators, etc.).
- Strong air currents on the detector (fans, air conditioning, etc.).
- Large animals in a field of view (dogs, cats).

4. Mounting the Detector (fig. 1)

1. Lift off the cover plate (1) as shown.
2. Using a screwdriver, prise open the detector (2) and carefully remove the PCB (3), taking care not to touch the pyroelectric sensor (4).
3. Break out one or both cable entry hole(s) (5), as required.
4. Select the mounting holes for corner (6) or flat wall (7) mounting.
5. Using the base as a template, mark the screw hole locations on the wall.
Mount the detector between 1.8 to 3.0 m high (fig. 4).
6. Fix the base to the wall.
7. Strip the cable 5 cm and pull it through the cable entry hole(s) (6) and strain relief (fig. 2).
8. Replace the PCB (3).
9. Wire the detector (fig. 5).
10. Select the detector address using the DIP switch (fig. 5).
11. Replace the cover (2), insert the screw (8) and replace the cover plate (1) (fig. 1)

5. Selecting the Coverage Pattern (fig. 6)

The coverage pattern can be changed to fit specific requirements using the mirror stickers. It is recommended to blind unused curtains that are looking at walls or windows located very close to the detector.

For example: See Fig. 4 for the mirror curtain coverage pattern corresponding to curtain 2A and 2B, 7A and 9B masked.

 **CAUTION!** Removing label(s) can damage the mirror surface!
Note: Under optimal conditions the range of the detector can be up to 100% higher than that stated.

6. Window Masking (figs. 7 - 8)

The window blinders are fitted ex-factory to the inside of the detector window. By partly masking the curtains in this way the detector will be more stable during normal use (fig. 7.)

When objects are located within 1.5 m or underneath the detector, insert the mask to the inside window (fig. 8). In particular, use the mask to avoid objects that change temperature (e.g. drinks machines, caged birds, etc.) and with reflective surfaces.

7. Setting the Detector

The following settings can be addressed by the PID bus:

Detector setting	Options
Walk test:	On/Off
Day/Night:	On/Off
Process mode:	3D+ or Bi-curtain
Range:	10 m or 16 m

The status of alarm and tamper can be read through the Bus via the ATS1290 DGP menu 2.

8. Resetting the Condition

Detector status	Condition for reset
PIR Alarm	3 sec. time-out.
PIR Latched alarm	Next change from Disarm to Arm .
PIR Trouble	Next successful PIR alarm. Next successful automatic test (every 10 minutes during Disarm).

9. LED Indication

Detector status	Red LED	☀ = On ☀ = Blinking
Power on	☀	Blinks alternately for 20 sec.
Alarm	☀	On during alarm period.
PIR Trouble	—	Blinks slowly until reset.
Low Battery	☀	Always on until correct voltage is restored (only in Walk Test mode).
Latch alarm	☀	Blinks until reset (not displayed during Walk Test).

10. Topology and Detectors

Please refer to the ATS1290 manual.

11. Cable Specification

Please refer to the ATS1290 manual.

12. The ATS Output (* see Memory Location Map below)

The ATS output can be used to enable/disable the alarm LED or Walk test LED on the detector.

The ATS output and zone numbering are equivalent.

The default output number for activating a walk test of the device equals the input number when memory location 6 is set to 0 (default).

The default output number for activating a Day/Night status of the device equals the input number +1 when memory location 7 is set to 0 (default).

Refer to the PID DGP manual for PID address settings and zone numbering.

The output number on the EV435-AD can also be changed within the DGP output range (i.e. DGP 1 output 17-32).

If the output for a walk test, of this device or all the outputs of similar devices on the same DGP need to be programmed on i.e. output 32, program memory location 6 of all those I/O devices to 32.

The same programming is applicable for memory location 7 for the Day/Night status.

The walk test and Day/Night (or arm / disarm) functionality can be programmed via event flags and output through the control panel.

13. Memory Location Map

Every addressable device has its own characteristics concerning related I/O lines or certain functionality of the device.

A total of 16 memory locations are reserved to configure the PID devices. Only the first 9 normally are user configurable. This depends on the functionality of the particular device.

For the EV435-AD, only the first seven memory locations are relevant.

14. Technical Specifications

Specified mounting height	min. 1.8 m - max. 3.0 m
Target speed range	min. 0.1 - max. 4.0 m/sec
Temperature range	-18 °C to +55 °C
Alarm time	min. 2.5 sec.
Relative humidity	max. 93%
Dimensions	103 x 71 x 53 mm
Weight	120 g
Number of zones	9
Max. detection range	16 m
IP/IK rating (with sealed cable entry)	IP30 IK02
Category	PR
Device type	T3
Bus protocol	Interlogix Point ID
Bus voltage	12 or 24 V
Current consumption out of bus	2.5 mA
Unit load for DGP	8.3
Address range	0 to 255

When disconnecting the detector from the bus, wait one minute before reconnecting it to ensure a clean boot.

Memory Location map for the EV435-AD

Location	Function	Direction	Value returned on READ CONFIG [Binary values]
3	Range	RW	0000 0000 = High sensitivity (default) 0000 0001 = Low sensitivity
4	Process Mode	RW	0000 0000 = 3D+ (default)
6	Walk Test output	RW	0000 0000 = Walk Test output number
7	Day/Night output	RW	0000 0000 = Day/Night output number

